



**HSUTECH ENTERPRISE CO.,LTD**

15F-8, No77, Shizheng N.1st Rd., Xitun Dist.,  
Taichung City 407563, Taiwan  
E-mail: sales@hsutech.com  
Tel: +886-4-23763211 Fax: +886-4-23762495  
Web: www.hsutech.com







HSUTECH ENTERPRISE CO. LTD was founded in 2006, we have been strived to bring the best tool technology into the market and continue investing HSUTECH family- look advanced design air tools, which we keep introducing these advancements to our overseas customers. Products from HSUTECH have been strictly tested to hold up to the rigors and demands of today's automotive & industrial markets.

With more than 30 years experience in the professional markets, very strong manufacturers support to provide high quality air tools yet very competitive price, which is our priority task. Contact HSUTECH now, we assure you having quality air tools with the best tool technology in your hands.



[www.hsutech.com](http://www.hsutech.com)





Viton oil seal to prevent oil leakage and excellent resistance to petroleum products. Good high temperature and low compression characteristic.

Well balanced and lightweight (1.6 kg), with an ergonomic composite handle



Patented double air intake motor system; delivers the highest torque in an absolutely compact air wrench



One handed operation, easy to switch Forward and Reverse by a thumb; setting with 2 speeds of forward and 1 speed of reverse

**Normal Air Intake**

Secondary Exhaust

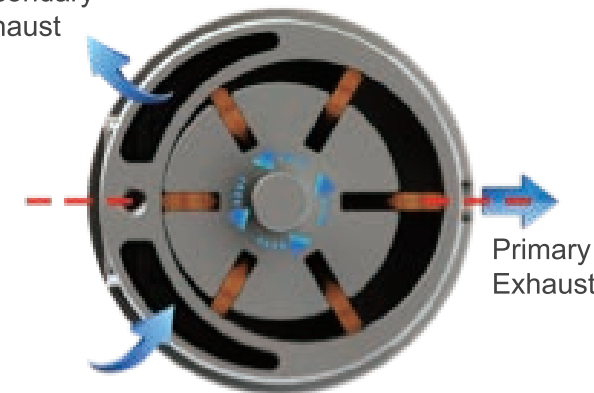

Primary Exhaust

**PAT. Twin Turbo Technology**

Primary Exhaust

Secondary Exhaust

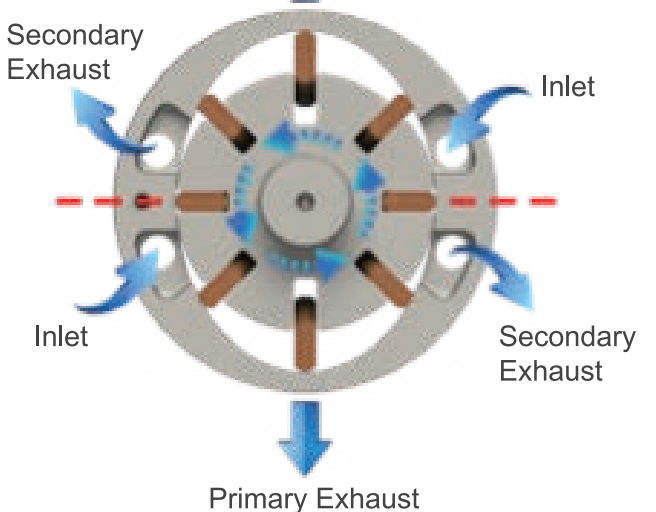

Secondary Exhaust

Primary Exhaust

**Features and Benefits:**

1. Revolutionary patented twin turbo motor system, Innovative design increased air intake flow delivers high torque in a compact machine.
2. One handed switch for 2 speeds forward, 1 speed reverse.
3. The shortest length for better access in tight areas.
4. Ergonomics comfort handle with well-balanced for users friendly.
5. Viton oil seal to prevent oil leakage under high performance and high temperature.
6. Front and end rotor plate insert a thin steel plate to prevent wear, keeps high performance.
7. Cold resistance against -25°C for composite motor housing.
8. Complicated processing, special material of rotor blade to provide wear resistance & very long life.

Impact wrench

Ratchet Wrench

0.35HP Air Tool

0.5HP Air Tool

Rust And Paint Remove Tool

1HP Air Die Grinder

Hyd. Air Riveter

Air Cutting Tool

Air Sander

Air Hammer & Needle Scaler

Clean & Foam Gun

Air Micro Grinder

Impact wrench

Ratchet Wrench

0.35HP Air Tool

0.5HP Air Tool

Rust And Paint Remove Tool

1HP Air Die Grinder

Hyd. Air Riveter

Air Cutting Tool

Air Sander

Air Hammer &amp; Needle Scaler

Clean &amp; Foam Gun

Air Micro Grinder

## HIW-04891J

### 1/2" MINI JUMBO TURBO COMPOSITE AIR IMPACT WRENCH

- The Jumbo Hammer mechanism has the simplest structure but produce a max torque output
- Compress not only the air but the money and time
- Extreme dissolving power in short and lightweight housing only 112 mm and 1.3 KGS
- Ideal for tight and hard to reach building spaces

**High Torque**  
**Light Weight**

## HIW-04892T

### 1/2" MINI TWIN TURBO COMPOSITE AIR IMPACT WRENCH

- The twin turbo system, which has two air inputs and four air outlets, allows maximum torque to reach maximum power faster
- Compress not only the air but the money and time
- Extreme dissolving power in short and lightweight housing only 129 mm and 1.3 KGS
- Ideal for tight and hard to reach building spaces

**High Torque**  
**Light Weight**

## HIW-04891T

**BEST CHOICE**

### 1/2" TWIN TURBO COMPOSITE AIR IMPACT WRENCH

- The twin turbo system, which has two air inputs and four air outlets, allows maximum torque to reach maximum power faster
- Compress not only the air but the money and time
- Extreme dissolving power in short and lightweight housing only 150 mm and 1.6 KGS
- Ideal for tight and hard to reach building spaces

**High Torque**  
**Light Weight**

## HIW-06894T

### 3/4" MINI TWIN TURBO COMPOSITE AIR IMPACT WRENCH

- The twin turbo system, which has two air inputs and four air outlets, allows maximum torque to reach maximum power faster
- Powerful in extremely reduced size and weight - only 155 mm and 1.8 KGS
- Compact design, optimized for work in confined spaces
- Working in comfort - reduced vibrations and easy handling

**High Torque**  
**Light Weight**

MODEL	Square Drive (inch)	Free Speed (RPM)	Max.Torque (ft.Lb (Nm))	Overall Length (mm)	Air Inlet (inch)	Air Hose I.D (inch (mm))	Avg. Air Consumption (cm <sup>3</sup> (L/min))	Noise Level (dBA)	Vibration (M/S <sup>2</sup> )	Net Weight (KG)
HIW-04891J	1/2"	10000	500(678)	112	1/4"	3/8"(10)	4.7(133)	91	9.69	1.3
HIW-04892T	1/2"	11000	500(678)	129	1/4"	3/8"(10)	4.0(113)	92.5	8.39	1.3
HIW-04891T	1/2"	8300	1000(1356)	150	1/4"	3/8"(10)	8.6(244)	99.7	8.69	1.6
HIW-06894T	3/4"	8000	1100(1485)	155	1/4"	3/8"(10)	5.0(142)	99.3	11.39	1.8

Recommended Air Pressure 90 psi (6.3 bar)

## HIW-06892T

### 3/4" TWIN TURBO COMPOSITE AIR IMPACT WRENCH

- The twin turbo system, which has two air inputs and four air outlets, allows maximum torque to reach maximum power faster
- Powerful in reduced size and weight - only 213 mm and 4.5 KGS
- Compact design, optimized for work in confined spaces
- Working in comfort - reduced vibrations and easy handling

**High Torque**  
**Light Weight**

## HIW-06892T-6

### 3/4" TWIN TURBO COMPOSITE AIR IMPACT WRENCH W/ 6" ANVIL

- The twin turbo system, which has two air inputs and four air outlets, allows maximum torque to reach maximum power faster
- Powerful in reduced size and weight - only 370 mm and 5.5 KGS
- Spindle length 186 mm - for reaching deeply located screw connections
- Compact design, optimized for work in confined spaces
- Working in comfort - reduced vibrations and easy handling

**High Torque**  
**Light Weight**

## HIW-08892T

### 1" TWIN TURBO COMPOSITE AIR IMPACT WRENCH

- The twin turbo system, which has two air inputs and four air outlets, allows maximum torque to reach maximum power faster
- Extended life span and decent efficiency in industrial and automotive applications
- Powerful in reduced size and weight - only 240 mm and 4.6 K
- Short and compact design, optimized for work in confined spa
- Working in comfort - reduced vibrations and easy handling

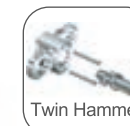
**High Torque**  
**Light Weight**

## HIW-08892T-8

### 1" TWIN TURBO COMPOSITE AIR IMPACT WRENCH W/ 8" ANVIL

- The twin turbo system, which has two air inputs and four air outlets, allows maximum torque to reach maximum power faster
- Extended life span and decent efficiency in industrial and automotive applications
- Powerful in reduced size and weight - only 370 mm and 5.9 KGS
- Short and compact design, with 240 mm long spindle, optimized for work in confined spaces
- Working in comfort - reduced vibrations and easy handling

**High Torque**  
**Light Weight**

MODEL	Square Drive (inch)	Free Speed (RPM)	Max.Torque (ft.Lb (Nm))	Overall Length (mm)	Air Inlet (inch)	Air Hose I.D (inch (mm))	Avg. Air Consumption (cm <sup>3</sup> (L/min))	Noise Level (dBA)	Vibration (M/S <sup>2</sup> )	Net Weight (KG)
HIW-06892T	3/4"	5200	1600(2170)	213	3/8"	1/2"(13)	8.6(244)	99.5	10.69	4.5
HIW-06892T-6	3/4"	5200	1490(2020)	370	3/8"	1/2"(13)	8.6(244)	102.5	9.02	5.5
HIW-08892T	1"	5200	1600(2170)	240	1/2"	1/2"(13)	8.3(235)	101.9	19.11	4.6
HIW-08892T-8	1"	4600	1300 (1762)	370	1/2"	1/2"(13)	8.3(235)	113.5	17.31	5.9

Recommended Air Pressure 90 psi (6.3 bar)



Impact wrench  
Ratchet Wrench  
0.35HP Air Tool  
0.5HP Air Tool  
Rust And Paint Remove Tool  
1HP Air Die Grinder  
Hyd. Air Riveter  
Air Cutting Tool  
Air Sander  
Air Hammer & Needle Scaler  
Clean & Foam Gun  
Air Micro Grinder

# FLEXIBLE ANGLE IMPACT WRENCH TWIN TURBO SERIES

**Breaking through space barriers without hassle!! Handy & Powerful Torque Output**

### Twin Hammer Mechanism

Durable, less vibration, excellent balance and no reaction force. Ultra short length 71mm only. (Anvil excluded)



Variable speed trigger

### 120° Flex-Head

The head can 60 degree bend over forward & backward respectively. Freely reach to the target bolt even in confined, restrained space.

### Tubeless Dual Air Channel

Air flows smoothly and sufficiently even though rotating the handle and motor housing.

### 360° Free Swivel Handle

The trigger is reachable by swivel handle, freely operating tool in any constrained space.

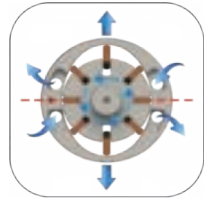

## HIW-A03450T

### 3/8" FLEX-HEAD ANGLE IMPACT WRENCH

- The twin turbo system, which has two air inputs and four air outlets, allows maximum torque to reach maximum power faster
- A flexible power player - 120° flexibility allows to reach those hidden bolts and any tight spaces
- Ultra-compact form factor, only 88 mm and 1.4 KGS, giving extra maneuverability
- 360° rotatable trigger with ergonomic handle
- Ultra-quiet operation at 84.8 dBA
- Low air consumption only at 4 cfm at 90 PSI



High Torque  
Light Weight



## HIW-A04500T

### 1/2" FLEX-HEAD ANGLE IMPACT WRENCH

- The twin turbo system, which has two air inputs and four air outlets, allows maximum torque to reach maximum power faster
- A flexible power player - 120° flexibility allows to reach those hidden bolts and any tight spaces
- Ultra-compact form factor, only 85 mm and 1.4 KGS, giving extra maneuverability
- 360° rotatable trigger with ergonomic handle
- Ultra-quiet operation at 84.8 dBA
- Low air consumption only at 4 cfm at 90 PSI

MODEL	Square Drive (inch)	Free Speed (RPM)	Max.Torque (ft.Lb (Nm))	Overall Length (mm)	Air Inlet (inch)	Air Hose I.D (inch (mm))	Avg. Air Consumption (cfm(L/min))	Noise Level (dBA)	Vibration (M/S <sup>2</sup> )	Net Weight (KG)
HIW-A03450T	3/8"	8500	369(500)	88	1/4"	3/8"(10)	4.0(113)	84.8	4.89	1.4
HIW-A04500T	1/2"	8000	369(500)	85	1/4"	3/8"(10)	4.0(113)	84.8	4.89	1.4

Recommended Air Pressure 90 psi (6.3 bar)

## HIW-A06100T

### 3/4" FLEX-HEAD TWIN TURBO ANGLE IMPACT WRENCH

- The twin turbo system, which has two air inputs and four air outlets, allows maximum torque to reach maximum power faster
- A flexible power player-120° flexibility allows to reach those hidden bolts and any tight spaces
- Ultra-compact form factor, only 126 mm and 2.3 KGS, giving extra maneuverability
- 360° rotatable trigger with ergonomic handle
- Ultra-quiet operation at 90.1 dBA
- Low air consumption only at 4.5 cfm at 90 PSI

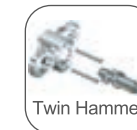

High Torque  
Light Weight



## HIW-P03450T

### 3/8" TWIN TURBO PALM IMPACT WRENCH

- The twin turbo system, which has two air inputs and four air outlets, allows maximum torque to reach maximum power faster
- 405 ft.lb of maximum reverse torque, 2X more powerful
- Palm fit and ultra-compact, only 85 mm and 1.1 KGS, perfect for confined areas
- Ultra-quiet operation at 91.1 dBA
- Low air consumption only at 3.4 cfm at 90 PSI

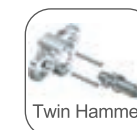

High Torque  
Light Weight



## HIW-P04500T

### 1/2" TWIN TURBO PALM IMPACT WRENCH

- The twin turbo system, which has two air inputs and four air outlets, allows maximum torque to reach maximum power faster
- 405 ft.lb of maximum reverse torque, 2X more powerful
- Palm fit and ultra-compact, only 85 mm and 1.1 KGS, perfect for confined areas
- Ultra-quiet operation at 92.9 dBA
- Low air consumption only at 3.4 cfm at 90 PSI

MODEL	Square Drive (inch)	Free Speed (RPM)	Max.Torque (ft.Lb (Nm))	Overall Length (mm)	Air Inlet (inch)	Air Hose I.D (inch (mm))	Avg. Air Consumption (cfm(L/min))	Noise Level (dBA)	Vibration (M/S <sup>2</sup> )	Net Weight (KG)
HIW-A06100T	3/4"	7500	738(1000)	126	3/8"	3/8"(10)	4.5(128)	90.1	4.89	2.3
HIW-P03450T	3/8"	7500	405(550)	85	1/4"	3/8"(10)	3.4(97)	91.1	7.24	1.1
HIW-P04500T	1/2"	7500	405(550)	85	1/4"	3/8"(10)	3.4(97)	92.9	7.64	1.1

Recommended Air Pressure 90 psi (6.3 bar)

Impact wrench

# ROTATABLE HEAD AIR ANGLE IMPACT WRENCH

Ratchet Wrench

0.35HP Air Tool

## HIW-A031282J

**3/8" ANGLE IMPACT WRENCH**

0.5HP Air Tool

## HIW-A041282J

**1/2" ANGLE IMPACT WRENCH**

- The Jumbo Hammer mechanism has the simplest structure but produce a max torque output
- Ultra-compact form factor, only 260 mm and 1.4 KGS, giving extra maneuverability
- 9,000 RPM of speed



360° Swivel exhaust lets you vent the air away from you body



Rust And Paint Remove Tool

1HP Air Die Grinder

## HIW-A031282XJ

**3/8" ANGLE IMPACT WRENCH**
**360° Rotatable Head With 8 positions**

Hyd. Air Riveter

## HIW-A041282XJ

**1/2" ANGLE IMPACT WRENCH**
**360° Rotatable Head With 8 positions**

Air Cutting Tool

Air Sander

- The Jumbo Hammer mechanism has the simplest structure but produce a max torque output
- Patented 360° rotatable wrench head, which equipped with 8 locking positions, creates a brand-new experience at work
- Ultra-short shank and ultra-compact form factor, only 260 mm and 1.5 KGS, giving extra maneuverability
- 8,000 RPM of speed



360° Swivel exhaust lets you vent the air away from you body



Air Hammer &amp; Needle Scaler

Clean &amp; Foam Gun

Air Micro Grinder

MODEL	Square Drive (inch)	Free Speed (RPM)	Max.Torque (ft.lb (Nm))	Overall Length (mm)	Air Inlet (inch)	HOSE Air Hose I.D (inch (mm))	Avg. Air Consumption (cfm(L/min))	Noise Level (dBA)	Vibration (M/S <sup>2</sup> )	Net Weight (KG)
HIW-A031282J HIW-A041282J	1/2" & 3/8"	9000	450(610)	260	1/4"	3/8"(10)	8.0 (210)	83	2.8	1.4
HIW-A041282XJ HIW-A031282XJ	1/2" & 3/8"	8000	450(610)	260	1/4"	3/8"(10)	8.0 (210)	91	2.8	1.5

Recommended Air Pressure 90 psi (6.3 bar)

## HIW-081838A-2

**SUPER DUTY 1" COMPOSITE AIR IMPACT WRENCH W/ 2" ANVIL**

- Rugged Front Cover-Aluminum metal for durability
- Upward/downward Plastic exhaust cover
- 3 Torque Settings
- Ergonomics Handle
- Inner/outer Trigger design

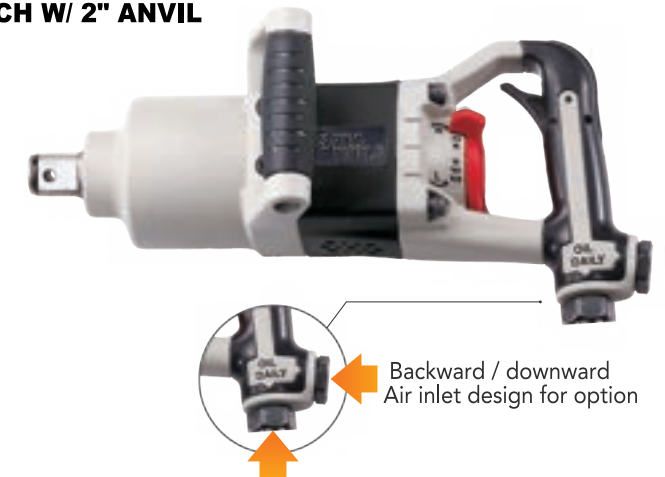
**High Torque  
Light Weight**

Backward / downward Air inlet design for option

Impact wrench

Ratchet Wrench

0.35HP Air Tool

0.5HP Air Tool

Rust And Paint Remove Tool

1HP Air Die Grinder

## HIW-0818T6

**SUPER DUTY 1" COMPOSITE AIR IMPACT WRENCH W/ 6" ANVIL**

- Rugged Front Cover-Aluminum metal for durability
- Upward/downward Plastic exhaust cover
- 3 Torque Settings
- Ergonomics Handle
- Inner/outer Trigger design

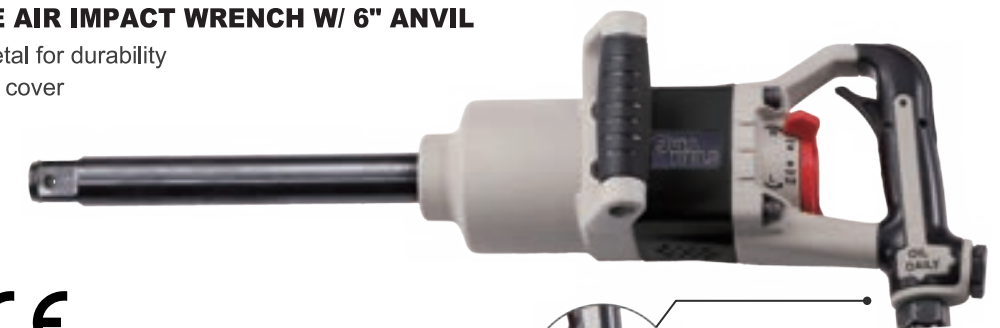
**High Torque  
Light Weight**

Backward / downward Air inlet design for option

Hyd. Air Riveter

Air Cutting Tool

## HIW-041475-A

**1/2" COMPOSITE AIR ANGLE IMPACT WRENCH**

- Precision Machined Bevel Gear, provides smooth transmission and prolonged tool life
- Jumbo Hammer Mechanism: Low recoil operation and High Instant toqure output
- Max reverse torque of 180 ft-lb ( 244 Nm) with 7,000 rpm free speed
- Ergonomic design with comfortable TPR grip
- Rear Exhaust: Discharges air away from the working area

**High Torque  
Light Weight**

Air Sander

Air Hammer &amp; Needle Scaler

Clean &amp; Foam Gun

Air Micro Grinder

MODEL	Square Drive (inch)	Free Speed (RPM)	Max.Torque (ft.lb (Nm))	Overall Length (mm)	Air Inlet (inch)	HOSE Air Hose I.D (inch (mm))	Avg. Air Consumption (cfm(L/min))	Noise Level (dBA)	Vibration (M/S <sup>2</sup> )	Net Weight (KG)
HIW-081838A-2	1"	5500	2200(2983)	370	1/2"	3/4"(19)	12.0 (340)	113.6	11.4	6.80
HIW-0818T6	1"	5500	2200(2983)	522	1/2"	3/4"(19)	12.0 (340)	113.6	11.4	7.70
HIW-041475-A	1/2"	7000	180(244)	343	1/4"	3/8"(10)	5.0 (142)	97	43.5	1.80

Recommended Air Pressure 90 psi (6.3 bar)



Impact wrench

Ratchet Wrench

0.35HP Air Tool

0.5HP Air Tool

Rust And Paint Remove Tool

1HP Air Die Grinder

Hyd. Air Riveter

Air Cutting Tool

Air Sander

Air Hammer &amp; Needle Scaler

Clean &amp; Foam Gun

Air Micro Grinder

## ULTRA COMPACT AIR IMPACT WRENCH SUPER MINI, HANDY & STEADY PERFORMANCE

**Industrial Application: Assembly, production, wooden constructing, bike maintenance and so on.**



### HIW-02503

#### 1/4" ALUMINUM IMPACT WRENCH

- The most compacted, the handiest, and the steadiest performance in your hand
- The best choice for industrial application, such as assembly, production, wooden construction, bike maintenance
- Ergonomic handle provides comfort and ideal balance given for operation
- Ultra-lightweight, powerful in reduced size and weight - only 134 mm and 0.9 KGS



Impact wrench

Ratchet Wrench

0.35HP Air Tool

0.5HP Air Tool

Rust And Paint Remove Tool

1HP Air Die Grinder

Hyd. Air Riveter

Air Cutting Tool

Air Sander

Air Hammer &amp; Needle Scaler

Clean &amp; Foam Gun

Air Micro Grinder

### HIW-03503

#### 3/8" ALUMINUM IMPACT WRENCH

- The most compacted, the handiest, and the steadiest performance in your hand
- The best choice for industrial application, such as assembly, production, wooden construction, bike maintenance
- Ergonomic handle provides comfort and ideal balance given for operation
- Ultra-lightweight, powerful in reduced size and weight - only 136 mm and 0.9 KGS



### HSD-503

#### ALUMINUM SCREW DRIVER

- The most compacted, the handiest, and the steadiest performance in your hand
- The best choice for industrial application, such as assembly, production, wooden construction, bike maintenance
- Ergonomic handle provides comfort and ideal balance given for operation
- Ultra-lightweight, powerful in reduced size and weight - only 144 mm and 0.9 KGS



MODEL	Square Drive (inch)	RPM Free Speed	Bolt Capacity (mm)	Max.Torque ft.lb (Nm)	Overall Length (mm)	Air Inlet (inch)	HOSE Air Hose I.D (inch (mm))	Avg. Air Consumption cm <sup>3</sup> (L/min)	Noise Level (dBA)	Vibration (M/S <sup>2</sup> )	Net Weight (KG)
HIW-02503	1/4"	10000	12	74(100)	134	1/4"	1/4"(6.35)	2.3(66)	86.9	5.4	0.9
HIW-03503	3/8"	10000	13	89(120)	136	1/4"	1/4"(6.35)	2.3(66)	86.9	5.4	0.9
HSD-503	X	10000	6-8	45(60)	144	1/4"	1/4"(6.35)	2.3(66)	86.9	5.4	0.9

Recommended Air Pressure 90 psi (6.3 bar)

## EXTREME MAGNESIUM IMPACT WRENCH SERIES

**Applicable in the general industrial use, construction, MRO (Maintenance, Repair and Overhaul), rail, heavy machinery, oil and gas, shipbuilding, vehicle repair industry, heavy trucks, tire lanes and fleet maintenance.**

### Key Advantages of Magnesium:

- Lightweight: 33% lighter than aluminum, 73% lighter than zinc, 80% lighter than steel
- Strength: 40% stronger than aluminum
- High Production Rate: 1.5 times the production rate of aluminum
- Perfect Vibration Damping Capacity: 25-40 times the dampening ability of aluminum
- Excellent Stiffness: 2 times the stiffness of aluminum
- Good Fatigue Resistance: Makes magnesium a favored structural metal
- Corrosion Resistance: 8 times better corrosion resistance than carbon steel & 4 times better than aluminum
- Unique Solubility: Soluble in aluminum. and produces useful aluminum-magnesium alloys
- Well Heat Sink: Similar thermal conductivity to aluminum, eliminate heat in the electronics industry



### HIW-03064J

**3/8" EXTREME MAGNESIUM IMPACT WRENCH**



### HIW-04079J

**1/2" EXTREME MAGNESIUM IMPACT WRENCH**



### HIW-04111T

**1/2" EXTREME COMPOSITE IMPACT WRENCH**

- Magnesium Alloy material
- Twin hammer mechanism with the reinforced process to enhance durability and steady powerful torque
- High precision machined steel alloy casting motor cylinder enables the long durability of air motor
- Three forward power setting; Full power reverse
- Sensitive trigger enables the multi-speed control
- Handle exhaust design



### HIW-04111T-2

**1/2" EXTREME COMPOSITE IMPACT WRENCH W/ 2" ANVIL**

- Magnesium Alloy material
- Twin hammer mechanism with the reinforced process to enhance durability and steady powerful torque
- High precision machined steel alloy casting motor cylinder enables the long durability of air motor
- Three forward power setting; Full power reverse
- Sensitive trigger enables the multi-speed control
- Handle exhaust design



### HIW-06135T

**3/4" MINI EXTREME COMPOSITE IMPACT WRENCH**

- Magnesium Alloy material
- Twin hammer mechanism with the reinforced process to enhance durability and steady powerful torque
- High precision machined steel alloy casting motor cylinder enables the long durability of air motor
- Three forward power setting; Full power reverse
- Sensitive trigger enables the multi-speed control
- Handle exhaust design



### HIW-06135T-6

**3/4" MINI EXTREME COMPOSITE IMPACT WRENCH W/ 6" ANVIL**

- Magnesium Alloy material
- Twin hammer mechanism with the reinforced process to enhance durability and steady powerful torque
- High precision machined steel alloy casting motor cylinder enables the long durability of air motor
- Three forward power setting; Full power reverse
- Sensitive trigger enables the multi-speed control
- Handle exhaust design

MODEL	Square Drive (inch)	Free Speed (RPM)	Max.Torque ft.Lb (Nm)	Overall Length (mm)	Air Inlet (inch)	HOSE Air Hose I.D (inch (mm))	Avg. Air Consumption cfm(L/min)	Noise Level (dBA)	Vibration (M/S <sup>2</sup> )	Net Weight (KG)
HIW-04111T	1/2"	8500	950(1283)	179	1/4"	3/8"(10)	5.5(158)	91.5	8.1	1.65
HIW-04111T-2	1/2"	8500	950(1283)	230	1/4"	3/8"(10)	5.5(158)	91.5	8.1	1.75
HIW-06135T	3/4"	8500	900(1215)	198	1/4"	3/8"(10)	5.5(158)	91.5	8.1	1.85
HIW-06135T-6	3/4"	8500	900(1215)	351	1/4"	3/8"(10)	5.5(158)	91.5	8.1	2.35

MODEL	Square Drive (inch)	Free Speed (RPM)	Max.Torque ft.Lb (Nm)	Overall Length (mm)	Air Inlet (inch)	HOSE Air Hose I.D (inch (mm))	Avg. Air Consumption cfm(L/min)	Noise Level (dBA)	Vibration (M/S <sup>2</sup> )	Net Weight (KG)
HIW-03064J	3/8"	8000	500(678)	141	1/4"	3/8"(10)	4.5(129)	89.5	4.7	1.0
HIW-04079J	1/2"	10000	600(814)	141	1/4"	3/8"(10)	4.5(129)	89.5	4.7	1.0

Recommended Air Pressure 90 psi (6.3 bar)

Recommended Air Pressure 90 psi (6.3 bar)



Impact wrench



## HIW-06198T

### 3/4" EXTREME COMPOSITE IMPACT WRENCH

- Magnesium Alloy material
- Twin hammer mechanism with the reinforced process to enhance durability and steady powerful torque
- High precision machined steel alloy casting motor cylinder enables the long durability of air motor
- Three forward power setting; Full power reverse
- Sensitive trigger enables the multi-speed control
- Handle exhaust design

**High Torque**  
**Light Weight**

Ratchet Wrench

0.35HP Air Tool

0.5HP Air Tool

Rust And Paint Remove Tool

1HP Air Die Grinder

Hyd. Air Riveter

Air Cutting Tool

Air Sander

Air Hammer &amp; Needle Scaler

Clean &amp; Foam Gun

Air Micro Grinder



## HIW-06198T-6

### 3/4" EXTREME COMPOSITE IMPACT WRENCH W/ 6" ANVIL

- Magnesium Alloy material
- Twin hammer mechanism with the reinforced process to enhance durability and steady powerful torque
- High precision machined steel alloy casting motor cylinder enables the long durability of air motor
- Three forward power setting; Full power reverse
- Sensitive trigger enables the multi-speed control
- Handle exhaust design

**High Torque**  
**Light Weight**

## HIW-08199T

### 1" MINI EXTREME COMPOSITE IMPACT WRENCH

- Magnesium Alloy material
- Twin hammer mechanism with the reinforced process to enhance durability and steady powerful torque
- High precision machined steel alloy casting motor cylinder enables the long durability of air motor
- Three forward power setting; Full power reverse
- Sensitive trigger enables the multi-speed control
- Handle exhaust design

**High Torque**  
**Light Weight**

## HIW-08199T-6

### 1" EXTREME COMPOSITE IMPACT WRENCH W/ 6" ANVIL

- Magnesium Alloy material
- Twin hammer mechanism with the reinforced process to enhance durability and steady powerful torque
- High precision machined steel alloy casting motor cylinder enables the long durability of air motor
- Three forward power setting; Full power reverse
- Sensitive trigger enables the multi-speed control
- Handle exhaust design

**High Torque**  
**Light Weight**

## HIW-08200T

### 1" EXTREME COMPOSITE IMPACT WRENCH (PISTOL TYPE)

- Magnesium Alloy material
- Twin hammer mechanism with the reinforced process to enhance durability and steady powerful torque
- High precision machined steel alloy casting motor cylinder enables the long durability of air motor
- Three forward power setting; Full power reverse
- Sensitive trigger enables the multi-speed control
- Handle exhaust design

**High Torque**  
**Light Weight**

Impact wrench

Ratchet Wrench

0.35HP Air Tool

0.5HP Air Tool

Rust And Paint Remove Tool

1HP Air Die Grinder

Hyd. Air Riveter

Air Cutting Tool

Air Sander

Air Hammer &amp; Needle Scaler

Clean &amp; Foam Gun

Air Micro Grinder



## HIW-08200T-6

### 1" EXTREME COMPOSITE IMPACT WRENCH (PISTOL TYPE) W/ 6" ANVIL

- Magnesium Alloy material
- Twin hammer mechanism with the reinforced process to enhance durability and steady powerful torque
- High precision machined steel alloy casting motor cylinder enables the long durability of air motor
- Three forward power setting; Full power reverse
- Sensitive trigger enables the multi-speed control
- Handle exhaust design

**High Torque**  
**Light Weight**

## HIW-08201T

### 1" EXTREME COMPOSITE IMPACT WRENCH (STRAIGHT TYPE)

- Magnesium Alloy material
- Twin hammer mechanism with the reinforced process to enhance durability and steady powerful torque
- High precision machined steel alloy casting motor cylinder enables the long durability of air motor
- Three forward power setting; Full power reverse
- Sensitive trigger enables the multi-speed control
- Handle exhaust design

**High Torque**  
**Light Weight**

MODEL	Square Drive (inch)	Free Speed (RPM)	Max.Torque (ftLb (Nm))	Overall Length (mm)	Air Inlet (inch)	Air Hose I.D (inch (mm))	Avg. Air Consumption (cm <sup>3</sup> /L/min)	Noise Level (dBA)	Vibration (M/S <sup>2</sup> )	Net Weight (KG)
HIW-06198T	3/4"	6000	1550(2092)	209	3/8"	3/8"(10)	7.0(198)	96.5	8.6	3.0
HIW-06198T-6	3/4"	6000	1550(2092)	362	3/8"	3/8"(10)	7.0(198)	96.5	8.6	3.6
HIW-08199T	1"	6000	1550(2092)	219	3/8"	3/8"(10)	7.0(198)	96.5	8.6	3.15
HIW-08199T-6	1"	6000	1550(2092)	372	3/8"	3/8"(10)	7.0(198)	96.5	8.6	3.75

Recommended Air Pressure 90 psi (6.3 bar)

MODEL	Square Drive (inch)	Free Speed (RPM)	Max.Torque (ftLb (Nm))	Overall Length (mm)	Air Inlet (inch)	Air Hose I.D (inch (mm))	Avg. Air Consumption (cm <sup>3</sup> /L/min)	Noise Level (dBA)	Vibration (M/S <sup>2</sup> )	Net Weight (KG)
HIW-08200T	1"	5500	2200(2970)	256	1/2"	1/2"(12)	7.5(212)	96.5	12.1	5.7
HIW-08200T-6	1"	5500	2200(2970)	417	1/2"	1/2"(12)	7.5(212)	96.5	12.1	6.6
HIW-08201T	1"	5500	2200(2970)	425	1/2"	1/2"(12)	7.5(212)	96.5	8.6	6.2

Recommended Air Pressure 90 psi (6.3 bar)

Impact wrench  
Ratchet Wrench  
0.35HP Air Tool  
0.5HP Air Tool  
Rust And Paint Remove Tool  
1HP Air Die Grinder  
Hyd. Air Riveter  
Air Cutting Tool  
Air Sander  
Air Hammer & Needle Scaler  
Clean & Foam Gun  
Air Micro Grinder



### HIW-08201T-6

#### 1" EXTREME COMPOSITE IMPACT WRENCH (STRAIGHT TYPE) W/ 6" ANVIL

- Magnesium Alloy material
- Twin hammer mechanism with the reinforced process to enhance durability and steady powerful torque
- High precision machined steel alloy casting motor cylinder enables the long durability of air motor
- Three forward power setting; Full power reverse
- Sensitive trigger enables the multi-speed control
- Handle exhaust design



**High Torque**  
**Light Weight** CE



### HIW-08201T-8

#### 1" EXTREME COMPOSITE (STRAIGHT TYPE) W/8" ANVIL IMPACT WRENCH

- Magnesium Alloy material
- Twin hammer mechanism with the reinforced process to enhance durability and steady powerful torque
- High precision machined steel alloy casting motor cylinder enables the long durability of air motor
- Three forward power setting; Full power reverse
- Sensitive trigger enables the multi-speed control
- Handle exhaust design



**High Torque**  
**Light Weight** CE



### HIW-06329T

#### 3/4" EXTREME COMPOSITE IMPACT WRENCH

- Magnesium Alloy material
- Twin hammer mechanism with the reinforced process to enhance durability and steady powerful torque
- High precision machined steel alloy casting motor cylinder enables the long durability of air motor
- Three forward power setting; Full power reverse
- Sensitive trigger enables the multi-speed control
- Handle exhaust design



**High Torque**  
**Light Weight** CE

MODEL	Square Drive (inch)	Free Speed (RPM)	Max.Torque ft.lb (Nm)	Overall Length (mm)	Air Inlet (inch)	HOSE Air Hose I.D (inch (mm))	Avg. Air Consumption cfm(L/min)	Noise Level (dBA)	Vibration (M/S <sup>2</sup> )	Net Weight (KG)
HIW-08201T-6	1"	5500	2200(2970)	580	1/2"	1/2"(12)	7.5(212)	96.5	8.6	7.2
HIW-08201T-8	1"	5500	2200(2970)	635	1/2"	1/2"(12)	7.5(212)	96.5	8.6	7.5
HIW-06329T	3/4"	7000	1600(2170)	357	3/8"	3/8"(10)	198(7)	98.5	8.6	3.6

Recommended Air Pressure 90 psi (6.3 bar)



### HIW-06329T-6

#### 3/4" EXTREME COMPOSITE IMPACT WRENCH W/ 6" ANVIL

- Magnesium Alloy material
- Twin hammer mechanism with the reinforced process to enhance durability and steady powerful torque
- High precision machined steel alloy casting motor cylinder enables the long durability of air motor
- Three forward power setting; Full power reverse
- Sensitive trigger enables the multi-speed control
- Handle exhaust design



**High Torque**  
**Light Weight** CE



### HIW-08330T

#### 1" EXTREME COMPOSITE IMPACT WRENCH

- Magnesium Alloy material
- Twin hammer mechanism with the reinforced process to enhance durability and steady powerful torque
- High precision machined steel alloy casting motor cylinder enables the long durability of air motor
- Three forward power setting; Full power reverse
- Sensitive trigger enables the multi-speed control
- Handle exhaust design



**High Torque**  
**Light Weight** CE



### HIW-08330T-6

#### 1" EXTREME COMPOSITE IMPACT WRENCH W/ 6" ANVIL

- Magnesium Alloy material
- Twin hammer mechanism with the reinforced process to enhance durability and steady powerful torque
- High precision machined steel alloy casting motor cylinder enables the long durability of air motor
- Three forward power setting; Full power reverse
- Sensitive trigger enables the multi-speed control
- Handle exhaust design



**High Torque**  
**Light Weight** CE

MODEL	Square Drive (inch)	Free Speed (RPM)	Max.Torque ft.lb (Nm)	Overall Length (mm)	Air Inlet (inch)	HOSE Air Hose I.D (inch (mm))	Avg. Air Consumption cfm(L/min)	Noise Level (dBA)	Vibration (M/S <sup>2</sup> )	Net Weight (KG)
HIW-06329T-6	3/4"	7000	1600(2170)	520	3/8"	3/8"(10)	198(7)	98.5	8.6	4.2
HIW-08330T	1"	7000	1600(2170)	357	3/8"	3/8"(10)	198(7)	98.5	8.6	3.7
HIW-08330T-6	1"	7000	1600(2170)	520	3/8"	3/8"(10)	198(7)	98.5	8.6	4.5

Recommended Air Pressure 90 psi (6.3 bar)

Impact wrench  
Ratchet Wrench  
0.35HP Air Tool  
0.5HP Air Tool  
Rust And Paint Remove Tool  
1HP Air Die Grinder  
Hyd. Air Riveter  
Air Cutting Tool  
Air Sander  
Air Hammer & Needle Scaler  
Clean & Foam Gun  
Air Micro Grinder



Impact wrench

Ratchet Wrench

0.35HP Air Tool

0.5HP Air Tool

Rust And Paint Remove Tool

1HP Air Die Grinder

Hyd. Air Riveter

Air Cutting Tool

Air Sander

Air Hammer &amp; Needle Scaler

Clean &amp; Foam Gun

Air Micro Grinder

## ECO POWER COMPOSITE AIR IMPACT WRENCH

Energy Saving,  
Lower Air Consumption  
Max. 25% Less

### Features & Benefits:

- **Lower Air Consumption = Save Cost**  
( Air compressor does not have to be frequently activated)
- Less Noise level : Workers will benefit from a better quality of life
- Provides a less stressful work environment
- Reduces noise pollution



3-position power regulation in Forward Full Power in Reverse



One-Hand Forward / Reverse Control



Solid Grip for the most comforts



Optional Silent Hose for Low Noise

### HIW-04986J

#### SUPER DUTY MINI 1/2" ECO POWER AIR IMPACT WRENCH

- Extremely short body with huge output torque for the tough nut in a confined area
- Ergonomic Comfort, Composite light-weight
- Refined Jumbo hammer impact mechanism provides max. torque **450 ft.lb (610 Nm)** output in reverse
- 3-position power setting regulator in forward & 1-position in reverse



### HIW-04986T



#### SUPER DUTY MINI 1/2" ECO POWER AIR IMPACT WRENCH

- Extremely short body with huge output torque for the tough nut in a confined area
- Innovative and easy-to-operate one-handed operation switch
- Ergonomic Comfort, Composite light-weight
- Refined Twin hammer impact mechanism provides max. torque **450 ft.lb (610 Nm)** output in reverse
- 3-position power setting regulator in forward & 1-position in reverse



Hammer pin anvil dog



### HIW-04987T

#### SUPER DUTY COMPACT 1/2" ECO POWER AIR IMPACT WRENCH

- Compact body with huge output torque for the tough nut in a confined area
- Innovative and easy-to-operate one handed operation switch
- Ergonomic Comfort, Composite light-weight
- Refined Twin hammer impact mechanism provides max. torque **550 ft.lb (750 Nm)** output in reverse
- 3-position power setting regulator in forward & 1-position in reverse



MODEL	Square Drive (inch)	Free Speed (RPM)	Max.Torque ft.lb (Nm)	Overall Length (mm)	Air Inlet (inch)	Air Hose I.D (inch (mm))	Avg. Air Consumption dm <sup>3</sup> /min	Noise Level (dBA)	Vibration (M/S <sup>2</sup> )	Net Weight (KG)
HIW-04986J	1/2"	9000	450 (610)	113	1/4"	3/8"(10)	4.1 (116)	91	9.69	1.2
HIW-04986T	1/2"	9000	450 (610)	122	1/4"	3/8"(10)	4.1 (116)	89	9.4	1.3
HIW-04987T	1/2"	7000	550 (750)	145	1/4"	3/8"(10)	4.4 (124)	95.4	7.2	1.6

Recommended Air Pressure 90 psi (6.3 bar)

Impact wrench

Ratchet Wrench

0.35HP Air Tool

0.5HP Air Tool

Rust And Paint Remove Tool

1HP Air Die Grinder

Hyd. Air Riveter

Air Cutting Tool

Air Sander

Air Hammer &amp; Needle Scaler

Clean &amp; Foam Gun

Air Micro Grinder



Impact wrench

## HIW-04900T **BEST CHOICE**

### SUPER DUTY 1/2" ECO POWER AIR IMPACT WRENCH

- Compact body with huge output torque for tough the nut in a confined area
- Innovative and easy-to-operate one-handed operation switch
- Ergonomic comfort, composite light-weight
- Refined Twin hammer impact mechanism provides max. torque **900 ft.lb (1220 Nm)** output in reverse
- 3-position power setting regulator in forward & 1-position in reverse



Ratchet Wrench

0.35HP Air Tool

0.5HP Air Tool

Rust And Paint Remove Tool

1HP Air Die Grinder

Hyd. Air Riveter

Air Cutting Tool

Air Sander

Air Hammer &amp; Needle Scaler

Clean &amp; Foam Gun

Air Micro Grinder

## HIW-04900TH

### SUPER DUTY 1/2" HI-TORQUE ECO POWER AIR IMPACT WRENCH

- Innovative and easy-to-operate one-handed operation switch
- Ergonomic Comfort, Composite light-weight
- Refined Twin hammer impact mechanism provides max. torque **1100 ft.lb (1492 Nm)** output in reverse
- 3-position power setting regulator in forward & 1-position in reverse



## HIW-06985T

### SUPER DUTY COMPACT 3/4" ECO POWER AIR IMPACT WRENCH

- Innovative and easy-to-operate one-handed operation switch
- Ergonomic Comfort, Composite light-weight
- Refined Twin hammer impact mechanism provides max. torque **1100 ft.lb (1492 Nm)** output in reverse
- 3-position power setting regulator in forward & 1-position in reverse



## HIW-04986JK HIW-04986TK

### 17 PCS MINI 1/2" COMPOSITE AIR IMPACT WRENCH KIT

Contents:

- 1 PC HIW-04986J (Jumbo hammer) / HIW-04986T(Twin hammer)
- 9 PCS 1/2" Mini Impact Sockets 13, 14, 15,16, 17, 18,19, 21, 24 mm
- 1 PC 1/2"Dr. x 3" Extension Bar
- 1 PC Oil Pot
- 1 PC Nipple
- 1 PC Blow Mold Case
- 3 PCS Thin wall impact sockets (CR-MO)17,19,21 mm
- PACKING 5 Sets / CTN / 13.5kg/ 14.5kg/ 1.3'

## HIW-04987TK

### 17 PCS MINI 1/2" COMPOSITE AIR IMPACT WRENCH KIT

Contents:

- 1 PC HIW-04987T ( Twin Hammer)
- 9 PCS 1/2" Mini Impact Sockets 13, 14, 15,16, 17, 18,19, 21, 24 mm
- 1 PC 1/2"Dr. x 3" Extension Bar
- 1 PC Oil Pot
- 1 PC Nipple
- 1 PC Blow Mold Case
- 3 PCS Thin wall impact sockets (CR-MO)17,19,21 mm
- PACKING 5 Sets / CTN / 13.5kg/ 14.5kg/ 1.3'



## HIW-04900TK

### 17 PCS 1/2" COMPOSITE AIR IMPACT WRENCH KIT

Contents:

- 1 PC HIW-04900T ( Twin Hammer )
- 10 PCS 1/2" Air Impact Sockets (Chrome-Molybdenum) 9, 10, 11, 13, 14, 17, 19, 22, 24, 27 mm
- 1 PC 1/2" Dr. x 5" Extension Bar
- 1 PC Oil Pot
- 1 PC 4 mm Hex Wrench
- 1 PC Nipple
- 1 PC Mini Oilier
- 1 PC Blow Mold Case
- PACKING 5 Sets / CTN / 20.2kg / 21.2kg / 1.6'

MODEL	Square Drive (inch)	Free Speed (RPM)	Max.Torque (ft.lb (Nm))	Overall Length (mm)	Air Inlet (inch (mm))	HOSE Air Hose I.D (inch (mm))	Avg. Air Consumption (cfm(L/min))	Noise Level (dBA)	Vibration (M/S <sup>2</sup> )	Net Weight (KG)
HIW-04900T	1/2"	6500	900(1220)	165	1/4"	3/8"(10)	4.80 (136)	91.6	9.44	2.02
HIW-04900TH	1/2"	5000	1100(1492)	186	1/4"	3/8"(10)	4.90 (139)	95	6.15	2.40
HIW-06985T	3/4"	5000	1100(1492)	191	1/4"	3/8"(10)	4.90 (139)	94.3	8.5	2.60

Recommended Air Pressure 90 psi (6.3 bar)

Impact wrench

Ratchet Wrench

0.35HP Air Tool

0.5HP Air Tool

Rust And Paint Remove Tool

1HP Air Die Grinder

Hyd. Air Riveter

Air Cutting Tool

Air Sander

Air Hammer &amp; Needle Scaler

Clean &amp; Foam Gun

Air Micro Grinder



Impact wrench

Ratchet Wrench

0.35HP Air Tool

0.5HP Air Tool

Rust And Paint Remove Tool

1HP Air Die Grinder

Hyd. Air Riveter

Air Cutting Tool

Air Sander

Air Hammer &amp; Needle Scaler

Clean &amp; Foam Gun

Air Micro Grinder

## SUPER DUTY COMPOSITE AIR IMPACT WRENCHES

### LIGHTWEIGHT BUT EXTREMELY HIGH TORQUE!

High strength aluminum alloy with undivided unit of and peak performance. Motor system provides the highest torque, durability.

PATENTED design composite and aluminum components provide lightweight, durability, cold-resistant and superior ergonomics design.

Alloy steel anvil with special heat treatment for durability.

Alloy steel twin hammer mechanism provides instantaneous highest torque value

Teasing trigger provides great control and operator comfort.

Handle exhaust directs the air away from operator and work piece.

Integrated power regulator with easy control dial with 3 speeds of forward and 3 speeds of reversed operation.

Contoured elastomer handle grip for improved comfort and ergonomics.



## HIW-04281T **BEST CHOICE**

### SUPER DUTY 1/2" COMPOSITE AIR IMPACT WRENCH

- Ergonomic Comfort, Composite light-weight
- Refined Twin hammer impact mechanism providing max. torque **1000ft.lb (1356 Nm)** output in reverse
- 3-position power setting regulator in forward & 2-position in reverse



Impact wrench

Ratchet Wrench

0.35HP Air Tool

0.5HP Air Tool

Rust And Paint Remove Tool

1HP Air Die Grinder

Hyd. Air Riveter

Air Cutting Tool

Air Sander

Air Hammer &amp; Needle Scaler

Clean &amp; Foam Gun

Air Micro Grinder

## HIW-06930T

### SUPER DUTY MINI 3/4" COMPOSITE AIR IMPACT WRENCH

- Ergonomic Comfort, Composite light-weight
- Refined Twin hammer impact mechanism providing max. torque **1000ft.lb (1356 Nm)** output in reverse
- 3-position power setting regulator in forward & 2-position in reverse



## HIW-06982T

### SUPER DUTY 3/4" COMPOSITE AIR IMPACT WRENCH

- Ergonomic Comfort, Composite light-weight
- Refined Twin hammer impact mechanism providing max. torque **1200ft.lb (1630Nm)** output in reverse
- 3-position power setting regulator in forward & 3-position in reverse



## HIW-08581T

### SUPER DUTY 1" COMPOSITE AIR IMPACT WRENCH

- Ergonomic Comfort, Composite light-weight
- Refined Twin hammer impact mechanism providing max. torque **1500ft.lb (2034Nm)** output in reverse
- 3-position power setting regulator in forward & 3-position in reverse



MODEL	Square Drive (inch)	Free Speed (RPM)	Max. Torque ft.lb (Nm)	Overall Length (mm)	Air Inlet (inch)	Air Hose I.D (inch (mm))	Avg. Air Consumption (cfm (l/min))	Noise Level (dBA)	Vibration (M/S <sup>2</sup> )	Net Weight (KG)
HIW-04281T	1/2"	10000	1000(1356)	193	1/4"	3/8"(10)	5.4(153)	93.7	4.4	2.02
HIW-06930T	3/4"	9000	1000(1356)	200	1/4"	3/8"(10)	5.4(153)	90	5.4	2.2
HIW-06982T	3/4"	5500	1200(1630)	221	3/8"	1/2"(12.7)	7.0(198)	92.8	5.9	3.6
HIW-08581T	1"	5300	1500(2034)	256	3/8"	1/2"(12.7)	7.0(198)	92	5.9	5.1

Recommended Air Pressure 90 psi (6.3 bar)



Impact wrench

## HRW-02604 (1/4") HRW-03603 (3/8")

### MINI AIR RATCHET WRENCH

- This compact / mini 1/4" Air Ratchet Wrench is only 125 mm long, making it ideal with tight work spaces like under dashboards or in engine bays
- It features a maximum torque of **22 ft.lb (30 Nm)**
- The cast aluminum body makes the air ratchet wrench lightweight and durable
- Cold-insulated handle grip



Ratchet Wrench

0.35HP Air Tool

## HRW-03603S (3/8")

### MINI AIR RATCHET WRENCH WITH DUAL-FUNCTION SCREWDRIVER BIT RETAINER

- This compact air ratchet handles with 1/4" Bit driver for a wide range of projects from removing automotive fasteners to assembly work
- The air ratchet wrench has a four-vane reversible motor with planetary gear reduction for a maximum torque of **22 ft.lb (30 Nm)**
- The cast aluminum body makes the air ratchet wrench lightweight and durable
- Cold-insulated handle grip and low-vibration



0.5HP Air Tool

Rust And Paint Remove Tool

1HP Air Die Grinder

## HRW-14602 (1/4") HRW-38601 (3/8")

### STUBBY AIR RATCHET WRENCH

- This air ratchet handles a wide range of projects from removing automotive fasteners to assembly work
- The air ratchet wrench has a four-vane reversible motor with planetary gear reduction for a maximum torque of **37 ft.lb (50Nm)**
- Cold-insulated handle grip and low-vibration



Hyd. Air Riveter

Air Cutting Tool

Air Sander

## HRW-38700 (3/8") HRW-12705 (1/2")

### 0.5 HP HEAVY DUTY AIR RATCHET WRENCH

- Rugged, variable speed, reversible air ratchet wrench
- Paddle-style trigger provides better speed control and the polyurethane handle grip helps maintain temperature and insulate vibration
- Unique ratchet head design ensures the wrench free of failure



Air Hammer &amp; Needle Scaler

Clean &amp; Foam Gun

Air Micro Grinder

MODEL	Square Drive (inch)	Free Speed (RPM)	Max. Torque (ft.lb (Nm))	Overall Length (mm)	Air Inlet (inch)	HOSE Air Hose I.D (inch (mm))	Avg. Air Consumption (cm <sup>3</sup> (L/min))	Noise Level (dBA)	Vibration (M/S <sup>2</sup> )	Net Weight (KG)
HRW-02604/03603	1/4" & 3/8"	300	22 (30)	125	1/4"	3/8" (10)	4.6 (130)	85	2.5	0.45
HRW-03603S	3/8"	300	22 (30)	125	1/4"	3/8" (10)	5.8 (165)	85	2.5	0.45
HRW-14602/38601	1/4" & 3/8"	230	37 (50)	165	1/4"	3/8" (10)	6.4 (180)	89	3.3	0.50
HRW-38700/12705	3/8" & 1/2"	175	50 (68)	265	1/4"	3/8" (10)	3.5 (99)	82	12.8/11	1.8

Recommended Air Pressure 90 psi (6.3 bar)

Impact wrench

## HRW-14206 (1/4") 27 Nm HRW-38306 (3/8") 54 Nm

### SUPER DUTY MINI AIR RATCHET WRENCH

- Delivers 200 rpm free speed with max torque
- Mini size - only 0.50 kg and 135 mm in length
- Head-sealed and full caged design prolongs the tool service life
- Compact and lightweight
- Design for long working duration and limited space applications



Ratchet Wrench

0.35HP Air Tool

## HRW-14223P (1/4") HRW-38323P (3/8")

### SUPER DUTY AIR IMPACT RATCHET WRENCH

- Equipped with the Unicorn™ Hammer clutch with reduced reaction force offering three times the work efficiency of the ordinary ratchets
- Max torque of **50 ft-lb (68 Nm)** with 700 rpm free speed Compact and Lightweight
- Ergonomic design for use in restricted spaces with optimized comfort

**SAFE & FASTER  
Low Reaction force**

0.5HP Air Tool

Rust And Paint Remove Tool

1HP Air Die Grinder

## HRW-38317 (3/8") HRW-12417 (1/2")

### SUPER DUTY AIR RATCHET WRENCH

- Max torque **80 ft-lb (108 Nm)** with free speed at 280 rpm
- Head-sealed and dual pawl ratchet design strengthens the torque output and extends tool life
- Popular for automotive garage work
- Exceptional performance ensures max productivity
- Textured rubber grip avoids slippage



Hyd. Air Riveter

Air Cutting Tool

Air Sander

## HRW-12974 (1/2") HIGH TORQUE Max. 180 Ft-lbs

### 0.9 HP HI-TORQUE 1/2" COMPOSITE AIR RATCHET WRENCH

- Extended length with the hi-torque **180 ft-lb (244 Nm)**, which provides the fastest rundown speed to remove any stubborn fasteners in a narrow working area
- Ergonomic and advanced composite housing for easy operation and anti-cold
- Built-in Speed regulator for easy adjustment



Safety Lever Trigger

Advanced Composite Housing

Air Hammer &amp; Needle Scaler

Clean &amp; Foam Gun

Air Micro Grinder

MODEL	Square Drive (inch)	Free Speed (RPM)	Max. Torque (ft.lb (Nm))	Overall Length (mm)	Air Inlet (inch)	HOSE Air Hose I.D (inch (mm))	Avg. Air Consumption (cm <sup>3</sup> (L/min))	Noise Level (dBA)	Vibration (M/S <sup>2</sup> )	Net Weight (KG)
HRW-14206/38306	1/4" & 3/8"	200/300	20(27) / 40(54)	135	1/4"	3/8" (10)	3.6 (103)	86/92	3.5/3.9	0.50
HRW-14223P/38323P	1/4" & 3/8"	700	50(68)	164	1/4"	3/8" (10)	3.1 (88)	90.6/89.6	8.61/13.7	0.60
HRW-38317/12417	3/8" & 1/2"	280	80(108)	260	1/4"	3/8" (10)	4 (113)	98.8/97.6	4.64/11	1.24
HRW-12974	1/2"	300	180(244)	318	1/4"	3/8" (10)	4.1 (116)	90	6.84	1.30

Recommended Air Pressure 90 psi (6.3 bar)



## 0.35 HP FAMILY LOOK MINI AIR TOOLS HANDY, POWERFUL, MAX. CONTROL

Twin-Bearing Spindle design provides super precise spindle and reduces vibration level

Ergonomic Cushion-Grip Handle design for extra on the job comfort Absorbs tool vibrations and protects your hand from the cold

Spindle Concentricity < 0.05 mm keeping all rotation components on the same centerline for reduced run-out and have lower vibration levels

Positive Stop regulator for more versatile performance on all kinds of jobs.

Swivel Exhaust

Super comfortable safety lever throttle to prevent accidental start ups.

High-Performance efficient 0.35 HP motor for extra torque, and extended durability.

### HAD-35125

#### MINI AIR ANGLE DIE GRINDER

- Angle head design for grinding, polishing, burnishing, and deburring, particularly for the areas that are difficult to access



### HAD-35115

#### 115° OFF-SET MINI AIR ANGLE DIE GRINDER

- 115° Air Angle Die Grinder is perfect for reaching tight or angled grinding jobs that inline die grinders just won't reach
- The 115° offset head provides a more ergonomic grinding position
- Ergonomically 115° offset head designed to the correct angle for proper wrist alignment and for sanding and grinding intricate shapes in cramped area



MODEL	COLLET SIZE inch(mm)	Free Speed RPM	Overall Length mm	AIR INLET inch	AIR HOSE I.D inch (mm)	Avg. Air Consumption cfm (L/min)	Vibration (M/S <sup>2</sup> )	Noise Level (dBA)	Net Weight KG
HAD-35125	1/4" (6)	20000	155	1/4"	3/8"(10)	2.6(74)	0.4	85	0.5
HAD-35115	1/4" (6)	20000	178	1/4"	3/8"(10)	2.6(74)	0.4	85	0.5

Recommended Air Pressure 90 psi (6.3 bar)

### HAD-35120

#### MINI AIR DIE GRINDER

- Ergonomic Cushion-Grip handle insulates against cold temperatures in the hand, helps ease user fatigue, and insulates against vibration
- Positive -Stop regulator for power / speed control and easy RPM adjustable. Help to more versatile performance on all kinds of jobs
- The rear swivel 360° exhaust (adjustable) - directs the air exhaust away from the user and working area
- Twin-bearing spindle design to provide super precise spindle concentricity less than 0.05 mm and minimal vibration
- Enhanced Grip Design & Low-profile Throttle Lever provide for extended run time without fatigue
- Rated 0.35 HP powerful air motor delivers the power you need for the toughest jobs



### HAD-351208

#### LOW SPEED MINI AIR DIE GRINDER

- Effective on Cast parts of aluminum, bronze and brass.
- An ideal tool for precision deburring and finishing on a variety of Surfaces.
- Providing higher torque with 7600 rpm effective on cast parts of aluminum, bronze and brass. Quickly and efficiently removes gates and parting lines in cast parts



### HAD-35120AL

#### 3" EXTENSION MINI AIR DIE GRINDER

- Extended shank straight Die Grinder features a comfortable feather trigger for excellent speed control. Ergonomically designed composite housing is mated to an extended head to reach into tight spots
- Ideal for porting, weld breaking and smoothing sharp edges, as well as deburring, polishing and grinding applications
- 25,000 rpm with variable speed control, a sturdy aluminum housing, rear exhaust and more



### HAD-35120L

#### 5" EXTENSION MINI AIR DIE GRINDER

- Extended shank straight Die Grinder features a comfortable feather trigger for excellent speed control
- Ergonomically designed composite housing is mated to an extended head to reach into tight spots
- Ideal for porting, weld breaking and smoothing sharp edges, as well as deburring, polishing and grinding applications
- 25,000 rpm with variable speed control, a sturdy aluminum housing, rear exhaust and more



MODEL	COLLET SIZE inch(mm)	Free Speed RPM	Overall Length mm	AIR INLET inch	HOSE Air Hose I.D inch (mm)	Avg. Air Consumption cfm(L/min)	Vibration (M/S <sup>2</sup> )	Noise Level (dBA)	Net Weight KG
HAD-35120	1/4"(6)	25000	155	1/4"	3/8"(10)	2.6(74)	0.4	85	0.4
HAD-351208	1/4"(6)	7600	185	1/4"	3/8"(10)	2.6(74)	0.4	85	0.5
HAD-35120AL	1/4"(6)	25000	220	1/4"	3/8"(10)	2.6(74)	0.4	85	0.5
HAD-35120L	1/4"(6)	25000	259	1/4"	3/8"(10)	2.6(74)	0.4	85	0.7

Recommended Air Pressure 90 psi (6.3 bar)

Impact wrench

Ratchet Wrench

0.35HP Air Tool

0.5HP Air Tool

Rust And Paint Remove Tool

1HP Air Die Grinder

Hyd. Air Riveter

Air Cutting Tool

Air Sander

Air Hammer &amp; Needle Scaler

Clean &amp; Foam Gun

Air Micro Grinder

Impact wrench

Ratchet Wrench

0.35HP Air Tool

0.5HP Air Tool

Rust And Paint Remove Tool

1HP Air Die Grinder

Hyd. Air Riveter

Air Cutting Tool

Air Sander

Air Hammer &amp; Needle Scaler

Clean &amp; Foam Gun

Air Micro Grinder



Impact wrench

Ratchet Wrench

0.35HP Air Tool

0.5HP Air Tool

Rust And Paint Remove Tool

1HP Air Die Grinder

Hyd. Air Riveter

Air Cutting Tool

Air Sander

Air Hammer &amp; Needle Scaler

Clean &amp; Foam Gun

Air Micro Grinder

## HAG-35121

### 2" MINI AIR ANGLE GRINDER

- Ideal for grinding work in confined areas
- Features rear exhaust with baffle for reduced noise level and safety throttle lever to stop accidental operation
- Suitable for professional workshop use



## HCT-35122

### 3" MINI AIR ANGLE CUTTER

- Ideal for cutting work in confined areas
- Features rear exhaust with baffle for reduced noise level and safety throttle lever to stop accidental operation
- Suitable for professional workshop use



## HAS-D35231

### 2" MINI AIR ANGLE DISC SANDER

- 90° Air Angle disc sander features an angle head for working in confined spaces
- The 13000 RPM free-speed angle sander with its lightweight for all types of sanding in confined areas



## HAS-35131

### 2" MINI SPOT REPAIR SANDER

- 2 mm orbital head for ultra-fine sanding and polishing
- The combined spindle-counter balance reduces vibration levels to 1.8m/sec. and adds reliability
- Precision alloy steel spiral-bevel gears extend tool life
- The internal silencing system reduces noise levels to 82dB and the composite grip adds operator comfort
- Ideal for professional auto techs
- The compact design and multiple attachments make this tool ideal for quick spot repair, polishing and refinishing



Orbital Dia. 2 mm

2" Triangle velcro 1.2" velcro

MODEL	Wheel / Pad (inch)	Free Speed (RPM)	Overall Length (mm)	AIR INLET (inch)	Air Hose LD (inch (mm))	Avg. Air Consumption (cfm (L/min))	Noise Level (dBA)	Vibration (MS <sup>-2</sup> )	Net Weight (KG)
HAG-35121	2"	15000	160	1/4"	3/8"(10)	2.6(74)	85	0.6	0.6
HCT-35122	3"	15000	160	1/4"	3/8"(10)	2.6(74)	85	0.6	0.7
HAS-D35231	2"	13000	155	1/4"	3/8"(10)	2.6(74)	86	0.6	0.8
HAS-35131	2"	13000	155	1/4"	3/8"(10)	2.6(74)	82	0.8	0.5

Recommended Air Pressure 90 psi (6.3 bar)

## 0.5HP LOW NOISE FAMILY LOOK AIR TOOLS

Twin Bearing Spindle design provides super precise spindle and reduces vibration level

Two-Tone Ergonomic Cushion-Grip Handle design for extra on the job comfort Absorbs tool vibrations and protects your hand from the cold

Spindle Concentricity < 0.05 mm keeping all rotation components on the same centerline for reduced run-out and have lower vibration levels

Positive Stop regulator for more versatile performance on all kinds of jobs.



Super comfortable safety lever throttle to prevent accidental start ups.

High Performance efficient 0.5 HP motor for extra torque, and extended durability.

Patented Low Noise Technology reduce the noise level to 80 dBA only rear air exhaust direct exhaust air away from workpiece.



## HAD-50210

### 90° RIGHT ANGLE HEAD AIR DIE GRINDER

- Ideal for high speed porting, blending and deburring
- Right angle head permits easy access to tight spots



Abrasive capacity: Carbide burrs, rotary files, mounted points, wheels and disc



## HAD-502115

### 115° OFFSET AIR DIE GRINDER

- Ergonomically 115° offset designed to the correct angle for proper wrist alignment and for sanding and grinding intricate shapes in cramped area

Abrasive capacity: Carbide burrs, rotary files, mounted points, wheels and disc

MODEL	COLLET SIZE (inch (mm))	Motor HP (W)	Free Speed (RPM)	Overall Length (mm)	Air Inlet (inch)	Air Hose LD (inch (mm))	Avg. Air Consumption (cfm (L/min))	Noise Level (dBA)	Vibration (MS <sup>-2</sup> )	Net Weight (KG)
HAD-50210	1/4"(6)	0.5(373)	18000	200	1/4"	3/8"(10)	3.5(99)	82	0.6	0.7
HAD-502115	1/4"(6)	0.5(373)	18000	200	1/4"	3/8"(10)	3.5(99)	82	0.6	0.7

Recommended Air Pressure 90 psi (6.3 bar)

Impact wrench

Ratchet Wrench

0.35HP Air Tool

0.5HP Air Tool

Rust And Paint Remove Tool

1HP Air Die Grinder

Hyd. Air Riveter

Air Cutting Tool

Air Sander

Air Hammer &amp; Needle Scaler

Clean &amp; Foam Gun

Air Micro Grinder



Impact wrench

Ratchet Wrench

0.35HP Air Tool

0.5HP Air Tool

Rust And Paint Remove Tool

1HP Air Die Grinder

Hyd. Air Riveter

Air Cutting Tool

Air Sander

Air Hammer &amp; Needle Scaler

Clean &amp; Foam Gun

Air Micro Grinder

Impact wrench

Ratchet Wrench

0.35HP Air Tool

0.5HP Air Tool

Rust And Paint Remove Tool

1HP Air Die Grinder

Hyd. Air Riveter

Air Cutting Tool

Air Sander

Air Hammer &amp; Needle Scaler

Clean &amp; Foam Gun

Air Micro Grinder



### HAD-50200

#### LOW NOISE STRAIGHT-LINE AIR DIE GRINDER

- Most comfortable cushioned die grinder perfect for delicate finishing work
- Can be used in various applications including porting, welding braking, deburring, polishing and grinding

Abrasive capacity:  
Carbide burs, rotary files, mounted points, wheels and disc



### HAD-50200AL

#### LOW NOISE 3" EXTENSION ARBOR AIR DIE GRINDER

- 3" Extension die grinder designed perfect for hard- to- reach area

Abrasive capacity:  
Carbide burs, rotary files, mounted points, wheels and disc



### HAD-50200L

#### LOW NOISE 5" EXTENSION ARBOR AIR DIE GRINDER

- 5" Extension die grinder designed perfect for hard- to- reach area

Abrasive capacity:  
Carbide burs, rotary files, mounted points, wheels and disc



**GEARED 3600 RPM**

### HAD-50265

#### LOW NOISE, LOW SPEED AIR DIE GRINDER

- Planetary geared low speed 3600 RPM provides extra high torque
- High torque and low speed make the tool ideal for tire buffing or pinstripe removal
- Great for using grinding wheels and flap wheels with surface conditioning materials



**GEARED 3600 RPM**

### HAD-50265L

#### LOW NOISE, LOW SPEED EXTENSION AIR DIE GRINDER

- Planetary geared low speed 3600 RPM provides extra high torque
- High torque and low speed make the tool ideal for tire buffing or pinstripe removal
- Great for using grinding wheels and flap wheels with surface conditioning material



Industrial collet

MODEL	Collet Size inch(mm)	Motor HP (W)	Free Speed (RPM)	Overall Length (mm)	Air Inlet (inch)	Air Hose I.D (inch (mm))	Avg. Air Consumption cm <sup>3</sup> (L/min)	Noise Level (dBA)	Vibration (M/S <sup>2</sup> )	Net Weight (KG)
HAD-50200	1/4"(6)	0.5(373)	22000	180	1/4"NPT	3/8"(10)	3.5(99)	81	0.6	0.6
HAD-50200AL	1/4"(6)	0.5(373)	22000	245	1/4"NPT	3/8"(10)	3.5(99)	79	0.6	0.7
HAD-50200L	1/4"(6)	0.5(373)	22000	285	1/4"NPT	3/8"(10)	3.5(99)	80	0.6	0.8
HAD-50265	1/4"(6)	0.5(373)	3600	210	1/4"NPT	3/8"(10)	3.5(99)	78	0.6	0.7
HAD-50265L	1/4"(6)	0.5(373)	3600	305	1/4"NPT	3/8"(10)	3.5(99)	79	0.6	1.0

Recommended Air Pressure 90 psi (6.3 bar)



### HRW-38700

#### LOW NOISE 3/8" AIR RATCHET WRENCH

- Great for efficiently fastening the screw to prevent too tightly and damage even in narrow space
- Two-Tone Ergonomic Cushion -Grip Handle design for extra on the job comfort, absorbs tool vibrations and protects your hand from the cold
- Positive stop regulator for more versatile performance on all kinds of jobs



### HRW-12705

#### LOW NOISE 1/2" AIR RATCHET WRENCH

- Great for efficiently fastening the screw to prevent too tightly and damage even in narrow space
- Two-Tone Ergonomic Cushion -Grip Handle design for extra on the job comfort, absorbs tool vibrations and protects your hand from the cold
- Positive stop regulator for more versatile performance on all kinds of jobs



MODEL	Square Drive inch (mm)	Max. Torque ft-lbs(Nm)	Motor HP (W)	Free Speed (RPM)	Overall Length (mm)	Air Inlet (inch)	Air Hose I.D (inch (mm))	Avg. Air Consumption cm <sup>3</sup> (L/min)	Noise Level (dBA)	Vibration (M/S <sup>2</sup> )	Net Weight (KG)
HRW-38700	3/8"(9.5)	50(67.8)	0.5(373)	175	270	1/4"	3/8"(10)	3.5(99)	79	0.6	0.8
HRW-12705	1/2"(12.7)	50(67.8)	0.5(373)	175	270	1/4"	3/8"(10)	3.5(99)	79	0.6	0.8

Recommended Air Pressure 90 psi (6.3 bar)



### HAS-D50231A

#### LOW NOISE 3" ANGLE DISC SANDER

- 15000 RPM great for using 2" (51 mm) or 3" (76 mm) locking type pad for all types of sanding on small areas



### HAS-D50232

#### 3" ORBITAL SANDER / POLISHER

- Idea for headlamp, windshield, small area repair and finish jobs

(2.5mm Orbital)

MODEL	Spindle Thread inch(mm)	Pad SIZE inch(mm)	Motor HP (W)	Free Speed (RPM)	Overall Length (mm)	Air Inlet (inch)	Air Hose I.D (inch (mm))	Avg. Air Consumption cm <sup>3</sup> (L/min)	Noise Level (dBA)	Vibration (M/S <sup>2</sup> )	Net Weight (KG)
HAS-D50231A	3/8"-24	2"-3"(51-76)	0.5(373)	15000	200	1/4"	3/8"(10)	3.5(99)	80	0.6	0.68
HAS-D50232	1/4"-20	3"(76)	0.5(373)	12000	185	1/4"	3/8"(10)	3.5(99)	80	0.6	0.7

Recommended Air Pressure 90 psi (6.3 bar)

Impact wrench

Ratchet Wrench

0.35HP Air Tool

0.5HP Air Tool

Rust And Paint Remove Tool

1HP Air Die Grinder

Hyd. Air Riveter

Air Cutting Tool

Air Sander

Air Hammer &amp; Needle Scaler

Clean &amp; Foam Gun

Air Micro Grinder



### HAS-D50227

#### LOW NOISE 5" AIR ANGLE SANDER / POLISHER

- Aggressive sanding action is great on metal for surface preparation and for sanding fiberglass
- Geared 4,000 rpm provides extra high torque, great for all kinds of sanding applications

### HAS-D50231L

#### LOW NOISE 3" EXTENSION AIR ANGLE POLISHER

- Remove dust nibs and scratches on base coat / clear coat paint systems

**GEARED  
2600 RPM**

MODEL	Spindle Thread inch(mm)	Pad Size inch(mm)	Motor HP (W)	Free Speed (RPM)	Overall Length mm	Air Inlet inch	Air Hose I.D inch (mm)	Avg. Air Consumption cm <sup>3</sup> (L/min)	Noise Level (dBA)	Vibration (M/S <sup>2</sup> )	Net Weight KG
HAS-D50227	5/16"-24	3"-5"(76-127)	0.5(373)	4000	(200)	1/4"	3/8"(10)	3.5(99)	80	0.6	1.0
HAS-D50231L	5/16"-24	3"(76)	0.5(373)	2600	(307)	1/4"	3/8"(10)	3.5(99)	80	0.6	1.2

Recommended Air Pressure 90 psi (6.3 bar)

 26041 3/8"x16NC  
 BT2749 M16x2  
 BT22750 M14x2  
 BT22751 8/5"x11NC  
 23138 1/4"x20

#### ADAPTER

 BT1650-05G 5" FINE GRAY POLISHING PAD  
 BT1650-05Y 5" COARSE YELLOW POLISHING PAD  
 BT1650-05W 5" WOOL WHEEL

 210K-9 3"ROLOC PAD  
 BT0B-38-3V0Y 3" 80g PAD (Hook-up)  
 BT0B-38-5V0 5" PAD (Hook-up)

 BT1650-03G 3" FINE GRAY POLISHING PAD  
 BT1650-03Y 3" COARSE YELLOW POLISHING PAD  
 BT165-03W 3" WOOL WHEEL

 26036-7 4" RUBBER ERASER  
 BT22748 6" STRIPPING WHEEL

Impact wrench

Ratchet Wrench

0.35HP Air Tool

0.5HP Air Tool

Rust And Paint Remove Tool

1HP Air Die Grinder

Hyd. Air Riveter

Air Cutting Tool

Air Sander

Air Hammer &amp; Needle Scaler

Clean &amp; Foam Gun

Air Micro Grinder



### HDR-38245K

#### LOW NOISE 3/8" NON-REVERSIBLE IN-LINE AIR DRILL

- In-Line Drill is designed for perfect drilling in hard-to-reach areas
- 2600 RPM low speed high torque great for drilling, sanding, polishing applications
- Positive stop regulator for more versatile performance on all kinds of jobs
- Equip with 3/8" Keyless chuck

### HDR-38265K

#### LOW NOISE 3/8" NON-REVERSIBLE IN-LINE AIR DRILL

- In-Line Drill is designed for perfect drilling in hard-to-reach areas
- 3600 RPM low speed high torque great for drilling, sanding, polishing applications
- Positive stop regulator for more versatile performance on all kinds of jobs
- Equip with 3/8" Keyless chuck

### HDR-38225A

#### LOW NOISE 3/8" 90° RIGHT ANGLE AIR DRILL

- Right angle head design great for drilling in all types materials, including sheet metal, wood and composites in restricted areas
- 1800 RPM low speed high torque resistance
- Positive stop regulator for more versatile performance on all kinds of jobs

MODEL	Spindle Thread inch(mm)	Chuck Size inch(mm)	Motor HP (W)	Free Speed (RPM)	Overall Length mm	Air Inlet inch	Air Hose I.D inch (mm)	Avg. Air Consumption cm <sup>3</sup> (L/min)	Noise Level (dBA)	Vibration (M/S <sup>2</sup> )	Net Weight KG
HDR-38245K	3/8"-24	3/8"(10)	0.5(373)	2600	215	1/4"	3/8"(10)	3.5(99)	79	0.6	0.8
HDR-38265K	3/8"-24	3/8"(10)	0.5(373)	3600	215	1/4"	3/8"(10)	3.5(99)	79	0.6	0.8
HDR-38225A	3/8"-24	3/8"(10)	0.5(373)	1800	205	1/4"	3/8"(10)	3.5(99)	81	0.6	0.9

Recommended Air Pressure 90 psi (6.3 bar)

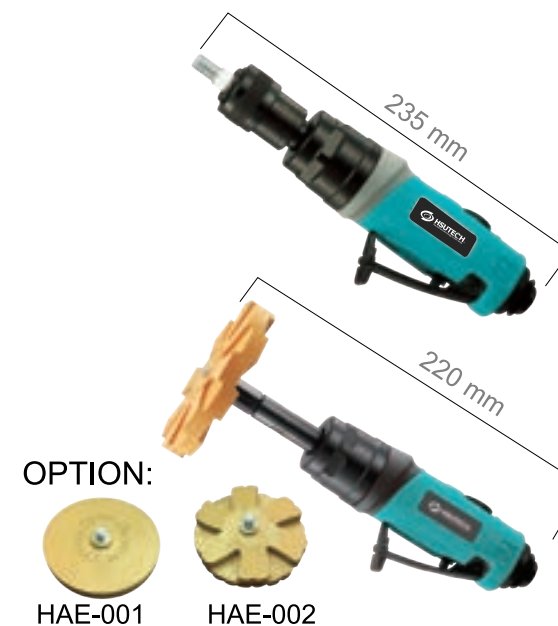

### HTB-50270

#### LOW NOISE AIR TIRE BUFFER

- 2600 RPM low-speed high torque great for tire buffering jobs
- Hexagonal chuck 11 mm, automatically centering chuck adapter for extremely high power without slipping
- Positive stop regulator for more versatile performance on all kinds of jobs

### HAE-50260

#### LOW NOISE AIR SMART ERASER

- Planetary geared 3600 RPM providing high torque, which is great for removing old letters, stickers, decals or decorative stripes without any damages on the surface
- A special 90 mm x 15 mm rubber wheel is included

MODEL	Spindle Thread inch(mm)	Chuck Size inch(mm)	Motor HP (W)	Free Speed (RPM)	Overall Length mm	Air Inlet inch	Air Hose I.D inch (mm)	Avg. Air Consumption cm <sup>3</sup> (L/min)	Noise Level (dBA)	Vibration (M/S <sup>2</sup> )	Net Weight KG
HTB-50270	3/8"-24	N/A	0.5(373)	2600	235	1/4"	3/8"(10)	3.5(99)	80	0.6	0.8
HAE-50260	5/16"-24	N/A	0.5(373)	3600	120	1/4"	3/8"(10)	3.5(99)	80	0.6	0.8

Recommended Air Pressure 90 psi (6.3 bar)



Impact wrench

Ratchet Wrench

0.35HP Air Tool

0.5HP Air Tool

Rust And Paint Remove Tool

1HP Air Die Grinder

Hyd. Air Riveter

Air Cutting Tool

Air Sander

Air Hammer &amp; Needle Scaler

Clean &amp; Foam Gun

Air Micro Grinder



### HAG-50230

#### LOW NOISE 2" AIR ANGLE GRINDER

- The Angle Grinder features versatile applications for grinding, including depressed disc



### HCT-50250

#### LOW NOISE 3" AIR CUT-OFF TOOL

- Cuts through bolts, shackles and steel rods up to 3/4" diameter
- Rips through sheet metal with ease
- Ideal for auto body and muffler repairs



### HCT-N50350

#### LOW NOISE AIR NIBBLER

- Ideal for cutting up to 18 gauge rolled steel and 14 gauge thin aluminum sheet metal in any configuration
- Provides a clean, smooth, accurate cut without distortion
- Cutting capacity 5.5 mm in radius with accuracy without distorted edges



### HCT-M50300

#### LOW NOISE STRAIGHT-LINE AIR METAL SHEAR

- Straight Air Shear is ideal for the trimming, outlining and shearing of various sheet metal
- Double-cut shear easily cuts through 14 gauge mild steel and stainless to 18 gauge without the need to file or deburr
- Ideal for the tinner, roofer and auto body shop



MODEL	Grinding Wheel inch(mm)	Cutting Capacity (mm)		Motor HP (W)	Free Speed (RPM)	Overall Length (mm)	Air Inlet (inch)	Air Hose I.D (inch (mm))	Avg. Air Consumption (cfm(L/min))	Noise Level (dBA)	Vibration (M/S <sup>2</sup> )	Net Weight (KG)
		Steel	Aluminum									
HAG-50230	2"(51)	N/A	N/A	0.5(373)	15000	180	1/4"	3/8"(10)	3.5(99)	81	0.6	0.71
HAG-50250	3"(76)	N/A	N/A	0.5(373)	21000	195	1/4"	3/8"(10)	3.5(99)	80	0.6	0.8
HCT-N50350	N/A	1.2	1.6	0.5(373)	2600	185	1/4"	3/8"(10)	3.5(99)	80	0.6	1.1
HCT-M50300	N/A	1.2	1.6	0.5(373)	2600	255	1/4"	3/8"(10)	3.5(99)	80	0.6	1.25

Recommended Air Pressure 90 psi (6.3 bar)

## HMSR-280K

### PROFESSIONAL 4" RUST AND PAINT REMOVAL TOOL KIT

- Rated 0.5 HP powerful air motor
- Innovative 180° rotational handle for precise leverage and control
- Unique double side safety guards and integrated dust extraction system for safe and clean operation
- Planetary gear system reinforces the high torque
- Ergonomic cushion grip insulates against cold and vibration
- Swivel exhaust outlet in rear of tool allows easy operation
- Paddle-style trigger for precise speed control
- Increase the baffle and prevent hands from being injured

#### H-E04

4" Eraser Wheel



#### H-ADP280

Wire Wheel Adaptor



#### H-RS04

Rib &amp; Strip Wheel



#### H-WW07

 Wire Wheel ( Coarse )  
 Wire Dia. : 0.7 mm  
 Wheel Dia. : 4" ( 103 mm )  
 Wheel width: 23 mm

#### H-WW05

 Wire Wheel ( Medium )  
 Wire Dia. : 0.5 mm  
 Wheel Dia. : 4" ( 103 mm )  
 Wheel width: 23 mm

#### H-WWS05

 Wire Wheel ( Fine )  
 Wire Dia. : 0.5 mm  
 Wheel Dia. : 4" ( 103 mm )  
 Wheel width: 23 mm

180° Rotational Handle

Kit



MODEL	Cutting Wheel inch(mm)	Spindle Thread inch(mm)	Free Speed (RPM)	Overall Length (mm)	Air Inlet (inch)	Air Hose I.D inch (mm)	Avg. Air Consumption cfm(L/min)	Noise Level (dBA)	Vibration (M/S <sup>2</sup> )	Net Weight (KG)
HMSR-280K	4"	1/4"(9)	4000	300	1/4"	3/8"(10)	3.5(99)	82	0.6	1.2

Recommended Air Pressure 90 psi (6.3 bar)

## HMSR-2943

### 1HP 4" EXTENDED AIR AXIAL RUST AND PAINT REMOVAL TOOL

- Low Profile head design for quick removal of corrosion rust or paint in tight area
- Extended & extremely low profile gear head permits to work in at areas that are difficult to reach
- Ideal for surface clean-up work
- Great for removing corrosion rust, sealants, or clean weld seam
- Metallically bright and thorough cleaning of surface
- Comfort Grip easy to Use Safety & Convenient
- Durable & Powerful at 1.0HP

#### OPTION:

#### H-WWS11-5

 Wire Wheel ( Fine )  
 Wire Dia. : 0.5 mm  
 Wheel Dia. : 4" ( 103 mm )  
 Wheel width: 0.43"(11mm)

#### H-WW11-5

 Wire Wheel ( Medium )  
 Wire Dia. : 0.5 mm  
 Wheel Dia. : 4" ( 103 mm )  
 Wheel width: 0.43"(11mm)

#### H-WW11-7

 Wire Wheel ( Coarse )  
 Wire Dia. : 0.7 mm  
 Wheel Dia. : 4" ( 103 mm )  
 Wheel width: 0.43"(11mm)

#### H-ADP294

 Wire Wheel Adaptor  
 Hub width 0.43"(11mm)

MODEL	Cutting Wheel inch(mm)	Spindle Thread (mm)	Free Speed (RPM)	Overall Length (mm)	Air Inlet (inch)	Air Hose I.D inch (mm)	Avg. Air Consumption cfm (L/min)	Noise Level (dBA)	Vibration (M/S <sup>2</sup> )	Net Weight (KG)
HMSR-2943	4"	1/4"(9)	3600	370	1/4"	3/8"(10)	3.6(101)	85	0.8	1.1

Recommended Air Pressure 90 psi (6.3 bar)

Impact wrench

Ratchet Wrench

0.35HP Air Tool

0.5HP Air Tool

Rust And Paint Remove Tool

1HP Air Die Grinder

Hyd. Air Riveter

Air Cutting Tool

Air Sander

Air Hammer &amp; Needle Scaler

Clean &amp; Foam Gun

Air Micro Grinder

## 1HP SUPER POWER AIR TOOLS

0.9 HP and 1 HP air grinders come with 1/4"(6mm) or 3/8"(8mm) with double angle collets for industrial application.

### HAD-290

#### 0.9HP AIR DIE GRINDER

- Die Grinder is suitable for many automotive and industrial high speed grinding applications.
- The grinder can be used to clean dies, rotors, backing plates and brake pad mounts
- Grind valve seats, dress welds and enlarge holes
- Can use with 1/4"(6mm) or 1/8"(3mm) grinding accessories
- Packing:12PCS / 9 / 9.8kgs/ 0.93'



### HAD-291

#### 0.9HP AIR ANGLE DIE GRINDER

- Angle Die Grinder is ideal for high speed grinding and polishing
- It can be used in finishing dies and metal molds, smoothing cast iron, weld finishing and other high-speed polishing application
- Can use with 1/4"(6mm) or 1/8"(3mm) grinding accessories
- Packing:12PCS / 11 / 12kgs/0.93'



### HAD-290AL

#### 1HP 3.5" AIR EXTENSION DIE GRINDER

- Extension die grinder is designed for high speed grinding and polish' in hard-to-reach areas
- Features an extended reach of 3.5"
- By using 1/4"(6mm) or 1/8"(3mm) grinding accessories, the grinder can be used in a wide range of grinding and polishing applic.
- Packing:12PCS / 10.7 / 11.7kgs / 1.1'



### HAD-290L

#### 1HP 5.5" AIR EXTENSION DIE GRINDER

- Extension die grinder is designed for high speed grinding and polishing in hard-to-reach areas
- Features an extended reach of 5.5"
- By using 1/4"(6mm) or 1/8"(3mm) grinding accessories, the grinder can be used in a wide range of grinding and polishing applications
- Packing 12PCS / 12 / 13kgs / 1.1'



MODEL	COLLET SIZE inch(mm)	Free Speed RPM	Overall Length (mm)	AIR INLET (inch)	Air Hose I.D inch (mm)	Avg. Air Consumption cm <sup>3</sup> (L/min)	Net Weight	
							Lbs	kgs
HAD-290	1/4"(6)	23000	180	1/4"	3/8"(10)	4.1(116)	1.1	0.5
HAD-291	1/4"(6)	18000	180	1/4"	3/8"(10)	4.1(116)	1.8	0.8
HAD-290AL	1/4"(6)	22000	240	1/4"	3/8"(10)	4.1(116)	1.8	0.8
HAD-290L	1/4"(6)	22000	280	1/4"	3/8"(10)	4.1(116)	2	0.9

Recommended Air Pressure 90 psi (6.3 bar)

## 1HP 12", 21-3/8", 31-1/2" Air Extension Die Grinder

\*The length of the extended body can be customized to extended as requirement.

**HAD-290L300 (22,000RPM) HAD-290L500 (22,000RPM) HAD-290L800 (22,000RPM)**  
**HAD-2965L300 (3,500RPM) HAD-2965L500 (3,500RPM) HAD-2965L800 (3,500RPM)**

#### 200E 29

6mm COLLET

#### 200E 29-1

1/4" COLLET

#### 200E29-2

8mm COLLET

#### 200E29-4

3/8" COLLET



### Benefits

- Industrial extended shaft long die grinder design for high speed grinding & polishing in hard-to-reach areas
- By using 1/4"(6mm) or 3/8"(8mm) double angle collets, the die grinder can be used in a wide range of grinding and polishing applications with various wheels
- 3500rpm models are excellent for grinding applications with flap sanding wheel
- High productivity
- Highest durability in demanding applications

### Features

- 12" (305 mm), 21-3/8" (543 mm), 31-1/2" (800 mm) extended body by aluminum alloy structure
- Comfort grip over-housing
- Streamlined safety lever
- Rear exhaust
- 1/4" (6mm) & 3/8" (8mm) industrial grade Double Angle collet holder
- 1.0 HP motor
- 22,000 rpm free speed models and 3,500 rpm free speed models

MODEL	COLLET SIZE inch(mm)	Free Speed RPM	Overall Length (mm)	AIR INLET (inch)	HOSE Air Hose I.D inch (mm)	Avg. Air Consumption cm <sup>3</sup> (L/min)	Net Weight	
							Lbs	kgs
HAD-290L300	1/4"(6)	22000	445	1/4"	3/8"(10)	4.24(120)	2.9	1.3
HAD-290L500	1/4"(6)	22000	688	1/4"	3/8"(10)	4.24(120)	3.9	1.8
HAD-290L800	1/4"(6)	22000	943	1/4"	3/8"(10)	4.24(120)	4.9	2.2
HAD-2965L300	1/4"(6)	3500	477	1/4"	3/8"(10)	4.24(120)	3.5	1.6
HAD-2965L500	1/4"(6)	3500	719	1/4"	3/8"(10)	4.24(120)	4.5	2
HAD-2965L800	1/4"(6)	3500	974	1/4"	3/8"(10)	4.24(120)	5.5	2.5

Recommended Air Pressure 90 psi (6.3 bar)

Impact wrench

Ratchet Wrench

0.35HP Air Tool

0.5HP Air Tool

Rust And Paint Remove Tool

1HP Air Die Grinder

Hyd. Air Riveter

Air Cutting Tool

Air Sander

Air Hammer & Needle Scaler

Clean & Foam Gun

Air Micro Grinder

Impact wrench

Ratchet Wrench

0.35HP Air Tool

0.5HP Air Tool

Rust And Paint Remove Tool

1HP Air Die Grinder

Hyd. Air Riveter

Air Cutting Tool

Air Sander

Air Hammer & Needle Scaler

Clean & Foam Gun

Air Micro Grinder



Impact wrench

Ratchet Wrench

0.35HP Air Tool

0.5HP Air Tool

Rust And Paint Remove Tool

1HP Air Die Grinder

Hyd. Air Riveter

Air Cutting Tool

Air Sander

Air Hammer &amp; Needle Scaler

Clean &amp; Foam Gun

Air Micro Grinder

Impact wrench

Ratchet Wrench

0.35HP Air Tool

0.5HP Air Tool

Rust And Paint Remove Tool

1HP Air Die Grinder

Hyd. Air Riveter

Air Cutting Tool

Air Sander

Air Hammer &amp; Needle Scaler

Clean &amp; Foam Gun

Air Micro Grinder

**HHR-101 | STANDARD**

 3/16" AIR-HYDRAULIC RIVETER  
 Jaw option: 2 or 3 Jaws

**HHR-101K | STANDARD**

3/16" AIR-HYDRAULIC RIVETER KIT

**HHR-103HD | STANDARD**

 1/4" AIR-HYDRAULIC RIVETER  
 Jaw option: 2 or 3 Jaws

**HHR-01P | INDUSTRIAL, COMPOSITE & VACUUM**

 3/16" INDUSTRIAL AIR-HYDRAULIC RIVETER  
**\*\* with Vacuum Function\*\***  
 3 Jaws (only)

**HHR-02P | INDUSTRIAL, COMPOSITE & VACUUM**

 3/16" INDUSTRIAL AIR-HYDRAULIC RIVETER  
**\*\* with Vacuum Function\*\***  
 3 Jaws (only)

**HHR-200 | HEAVY DUTY**

 3/16" AIR-HYDRAULIC RIVETER  
**\*\* Long Life Design \*\***  
 3 Jaws (only)

**HHR-300 | HEAVY DUTY**

 1/4" AIR-HYDRAULIC RIVETER  
**\*\* Long Life Design \*\***  
 3 Jaws (only)

**HHR-03P | INDUSTRIAL, COMPOSITE & VACUUM**

 1/4" INDUSTRIAL AIR-HYDRAULIC RIVETER  
**\*\* with Vacuum Function\*\***  
 3 Jaws (only)

**HHR-04P | INDUSTRIAL, COMPOSITE & VACUUM**

 1/4" INDUSTRIAL AIR-HYDRAULIC RIVETER  
**\*\* with Vacuum Function\*\***  
 3 Jaws (only)

MODEL	Traction Power		Blind Rivet Setting Capacity-inch (mm)	Stroke Length	AIR INLET inch	HOSE Air Hose I.D inch (mm)	Avg. Air Consumption (l/min)		Net Weight		MAX. Rivet Capacity		Packing Pos / CTN / NW / GW / Cwt (Kgs)
	Lbs	kgs					cfm	l/min	Lbs	kgs	AL.&Steel mm	Stainless mm	
HHR-101	2680	1219	3/32"-3/16" (2.4-4.8mm)	14	1/4"	3/8" (10)	3.5	123	3.3	1.5	4.8	4	10/CTN/18/19/1.85'
HHR-103HD	4166	1894	3/32"-3/16" (2.4-4.8mm)	19	1/4"	3/8" (10)	4.2	148	4.3	2	6.4	5.6	6/CTN/16/17/2'
HHR-200	1960	890	1/8" ~ 3/16" (3.2 - 4.8mm)	15.5	1/4"	3/8" (10)	3.5	123	3.74	1.7	4.8	4	10/CTN/20.7/21.7/2.58'
HHR-300	3130	1420	5/32" ~ 1/4" (4.0 ~ 6.4mm)	18	1/4"	3/8" (10)	4.2	148	4.4	2	6.4	5.6	8/CTN/20.4/21.4/2.28'

Recommended Air Pressure at 90 psi (6.2bar)

MODEL	Traction Power		Blind Rivet Setting Capacity-inch (mm)	Stroke Length	AIR INLET inch	HOSE Air Hose I.D inch (mm)	Avg. Air Consumption (l/min)		Net Weight		MAX. Rivet Capacity		Packing Pos / CTN / NW / GW / Cwt (Kgs)
	Lbs	kgs					cfm	l/min	Lbs	kgs	AL.&Steel mm	Stainless mm	
HHR-01P	1346	612	3.2- 4.0- 4.8mm	14	1/4"	3/8" (10)	1.2L	3.74	1.7	4.8	4	3/CTN/6.6/7.6/2.1'	
HHR-02P	2097	953	3.2 - 4.0 - 4.8mm	17	1/4"	3/8" (10)	2.1L	4.62	2.1	4.8	4.0	3/CTN/7.4/8.4/2.1'	
HHR-03P	2895	1316	4.0 - 4.8 - 6.4mm	26	1/4"	3/8" (10)	4.3L	5.06	2.3	6.4	4.8	3/CTN/8.3/9.3/2.1'	
HHR-04P	4194	1906	4.0 - 4.8 - 6.4mm	17	1/4"	3/8" (10)	4.3L	5.06	2.3	6.4	6.4	3/CTN/8.4/9.4/2.1'	

Recommended Air Pressure at 90 psi (6.2bar)



## HRN-01 | AUTOMATIC

M3~M12 Air Hydraulic Rivet Nut Tools  
**Capacity: M3,M4, M5, M6,M8,M10, M12**  
 Carry Blow Case

- Operating pressure : 80 ~ 100psi
- One-step Trigger
- Spin-on, pull-up & Spin-off Action
- Hydro-pneumatic Operation
- Lightweight & ergonomically Design



## HRN-02 | SEMI-AUTOMATIC

M10 Air Hydraulic Rivet Nut Tools  
**Capacity: M4,M5,M6,M8,M10**

Operating Pressure (PSI):  
 M4 : 58~65 PSI  
 M5 : 58~65 PSI  
 M6 : 80~85 PSI  
 M8 : 90~95 PSI  
 M10 : 90~95 PSI



MODEL	Rivet Nut Setting Capacity-inch mm	Traction Power		Stroke Length mm	Air Inlet inch	HOSE Air Hose I.D inch (mm)	Avg. Air Consumption (L/min)		Net Weight		MAX. Rivet Capacity		Packing Pos / CTN / MW / GW / Out (Kgs)
		Lbs	kgs				cfm	l/min	Lbs	kgs	AL.&Steel mm	Stainless mm	
HRN-01	M3,M4,M5,M6,M8,M10,M12	4565	2075	6	1/8"	3/8"(10)	1.12	31.7	5.24	2.38	M12	M10	2/CTN/11.3/12.3/1.98'
HRN-02	M4,M5,M6,M8,M10	2680	1214	6.5	1/4"	3/8"(10)	3	85	3.59	1.63	M10	M6	10/CTN/18.5/19.5/2.48'

Recommended Air Pressure at 90 psi (6.2bar)

## HCT-03252

### 3" FLEX HEAD REVERSIBLE CUT-OFF TOOL

- Can cut muffler and radiator clamps, bolts, sheet metal, fiberglass and steel rods
- Forward and reverse cutting direction, which can direct sparks away for personal safety
- Built-in adjustable power regulator
- Quick-Lock device for quick adjustable head position

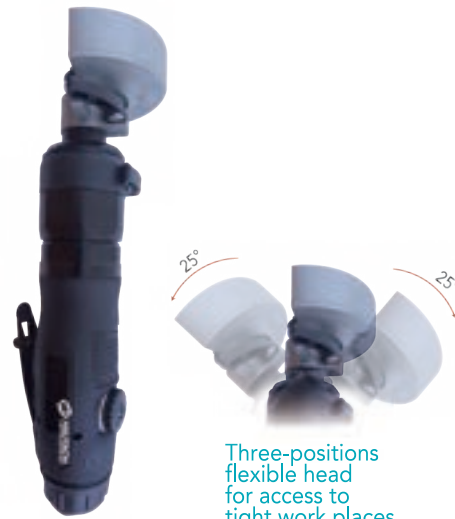

Three-positions flexible head for access to tight work places

MODEL	Cutting Wheel Size (inch)	Free Speed R.P.M	Spindle Thread inch(mm)	Overall Length (mm)	Air Inlet (inch)	HOSE Air Hose I.D inch (mm)	Avg. Air Consumption (L/min)	Noise Level (dBA)	Vibration (M/S <sup>2</sup> )	Net Weight (kg)
HCT-03252	3"	16000	M10x1.5	250	1/4"	3/8"(10)	3.6(102)	85	0.8	1.1

Recommended Air Pressure at 90 psi (6.2bar)

## HCT-29639

### 1 HP SUPER POWER 4" AIR ANGLE CUTTER

- Powerful 1HP air motor ideal for cutting composite, metal, exhaust pipes, hangers, body panels, hoses and U-bolts.
- Compact & low profile gear housing at 39 mm of height, which can easy to reach narrow space
- Composite ergonomic handle grip to reduce cold air transmission to the operator
- Spindle lock system for easier cutting wheel change
- Unique 9 positions adjustable swivel guard-120 degree adjustable for better operator protection & greater visibility of cutting operation
- Built-in speed regulator for easy adjustment
- Comfortable safety throttle lever to prevent accidental start ups
- Larger bearing size for better support internal gear
- High-quality alloy steel for spiral bevel gears with precision teeth design for tool longevity

#### Spindle Lock



## HCT-25439

### 0.75 HP 4" EXTENDED REVERSIBLE AIR AXIAL CUTTER

- Powerful 0.75 HP air motor great for cutting composite, metal, exhaust pipe, hangers, body panels, hoses and U-bolts especially in hard-to-reach areas.
- Compact & low profile gear housing at 39 mm of height, which easy to reach narrow space
- Unique reversible cutting design, which can direct sparks away for personal safety
- Spindle lock system for easier cutting disc replacement
- Postive stop Hi-Low regulator for more versatile performance on all types of jobs
- Ergonomic cushion grip for cold insulated and low vibration

#### Spindle Lock



## HCT- 49315

### 0.9 HP 4" EXTENDED AIR AXIAL CUTTER

- Ideal for separating cross rods and tie rods, supporting ball joints and exhaust pipes
- Combines the advantages of slim design with the power of traditional cutting tools overall length 375 mm

MODEL	Cutting Wheel inch(mm)	Spindle Thread inch(mm)	Free Speed RPM	Overall Length mm	Air Inlet inch	HOSE Air Hose I.D inch (mm)	Avg. Air Consumption cfm(L/min)	Noise Level (dBA)	Vibration (M/S <sup>2</sup> )	Net Weight (kg)
HCT-29639	4"(102)	M10x1.5	14000	230	1/4"	3/8"(10)	4.1(116)	85	1.5	1.0
HCT-29439	4"(102)	M10x1.5	14000	345	1/4"	3/8"(10)	4.1(116)	85	1.5	1.4
HCT-25439	4"(102)	M10x1.5	14000	370	1/4"	3/8"(10)	3.6(103)	88	1.9	1.1
HCT-49315	4"(102)	M10x1.5	15000	380	1/4"	3/8"(10)	4(113.2)	88	1.9	1.36

Recommended Air Pressure 90 psi (6.3 bar)

## HCT-29439

### 1 HP SUPER POWER 4" EXTENSION AIR ANGLE CUTTER



Impact wrench

Ratchet Wrench

0.35HP Air Tool

0.5HP Air Tool

Rust And Paint Remove Tool

1HP Air Die Grinder

Hyd. Air Riveter

Air Cutting Tool

Air Sander

Air Hammer &amp; Needle Scaler

Clean &amp; Foam Gun

Air Micro Grinder

Impact wrench

Ratchet Wrench

0.35HP Air Tool

0.5HP Air Tool

Rust And Paint Remove Tool

1HP Air Die Grinder

Hyd. Air Riveter

Air Cutting Tool

Air Sander

Air Hammer &amp; Needle Scaler

Clean &amp; Foam Gun

Air Micro Grinder



Impact wrench

Ratchet Wrench

0.35HP Air Tool

0.5HP Air Tool

Rust And Paint Remove Tool

1HP Air Die Grinder

Hyd. Air Riveter

Air Cutting Tool

Air Sander

Air Hammer &amp; Needle Scaler

Clean &amp; Foam Gun

Air Micro Grinder

## HCT-AV105

### VIBRATION-DAMPED MINI AIR BODY SAW

- Patented vibration reduced mechanism
- Light weight and compact design for comfort
- Safety trigger to prevent accidental start ups
- Rear exhaust direct air away from work piece



## HCT-BS354

**BEST CHOICE**

### PRO. NON-STOP GEARED AIR BODY SAW

- PAT. Gear-driven transmitted mechanism providing 200% more cutting capacity than standard air saw
- Unstoppable! Cuts up to 5 mm
- 10,500 spm powerful cutting can long-lasting saw blades life
- Innovative safety-lockout trigger design
- Ergonomic comfort rubber grip resistant to automotive fluids



## HCT-BS220

**BEST CHOICE**

### SUPER DUTY VIBRATION-DAMPED AIR SAW

- PAT. Gear-driven transmitted mechanism providing 200% more cutting capacity than standard air saw
- Unstoppable! Cuts up to 5 mm
- 5,000 spm powerful cutting can long-lasting saw blades life
- Innovative safety-lockout trigger design
- Ergonomic comfort rubber grip resistant to automotive fluids



#### OPTION:

### HSF-TO14 Swivel



### HSF-TO14R Swivel and regulator



MODEL	Stroke Length (mm)	Cutting Capacity Steel Plate (mm)	Stroke Per Min. S.P.M.	Overall Length (inch)	Air Inlet (inch)	Air Hose I.D (inch (mm))	Avg. Air Consumption (cm <sup>3</sup> /L/min)	Noise Level (dBA)	Vibration (M/S <sup>2</sup> )	Net Weight (KG)
HCT-AV105	10	3	9500	160	1/4"	3/8"(10)	3.5(99)	88	3	0.4
HCT-BS354	6	3	10500	230	1/4"	3/8"(10)	4(113.2)	85	2.1	0.8
HCT-BS220	11	5	5000	270	1/4"	3/8"(10)	3.5(99)	85	11.8	1

Recommended Air Pressure at 90 psi (6.2bar)

## HAS-BS706

**BEST CHOICE**

### PRO. HIGH SPEED COMPOSITE AIR BELT SANDER ( 10 MM X 330 MM)

## HAS-BS707

### PRO. HIGH-SPEED COMPOSITE AIR BELT SANDER (12.7 MM X 457 MM)

## HAS-BS709

### PRO. HIGH-SPEED COMPOSITE AIR BELT SANDER (30 MM X 540 MM)

## HAS-BS7076

### PRO. HIGH-SPEED COMPOSITE AIR BELT SANDER (12.7 MM X 330 MM)

## HAS-BS708

**BEST CHOICE**

### PRO. HIGH-SPEED COMPOSITE AIR BELT SANDER (20 MM X 520 MM)

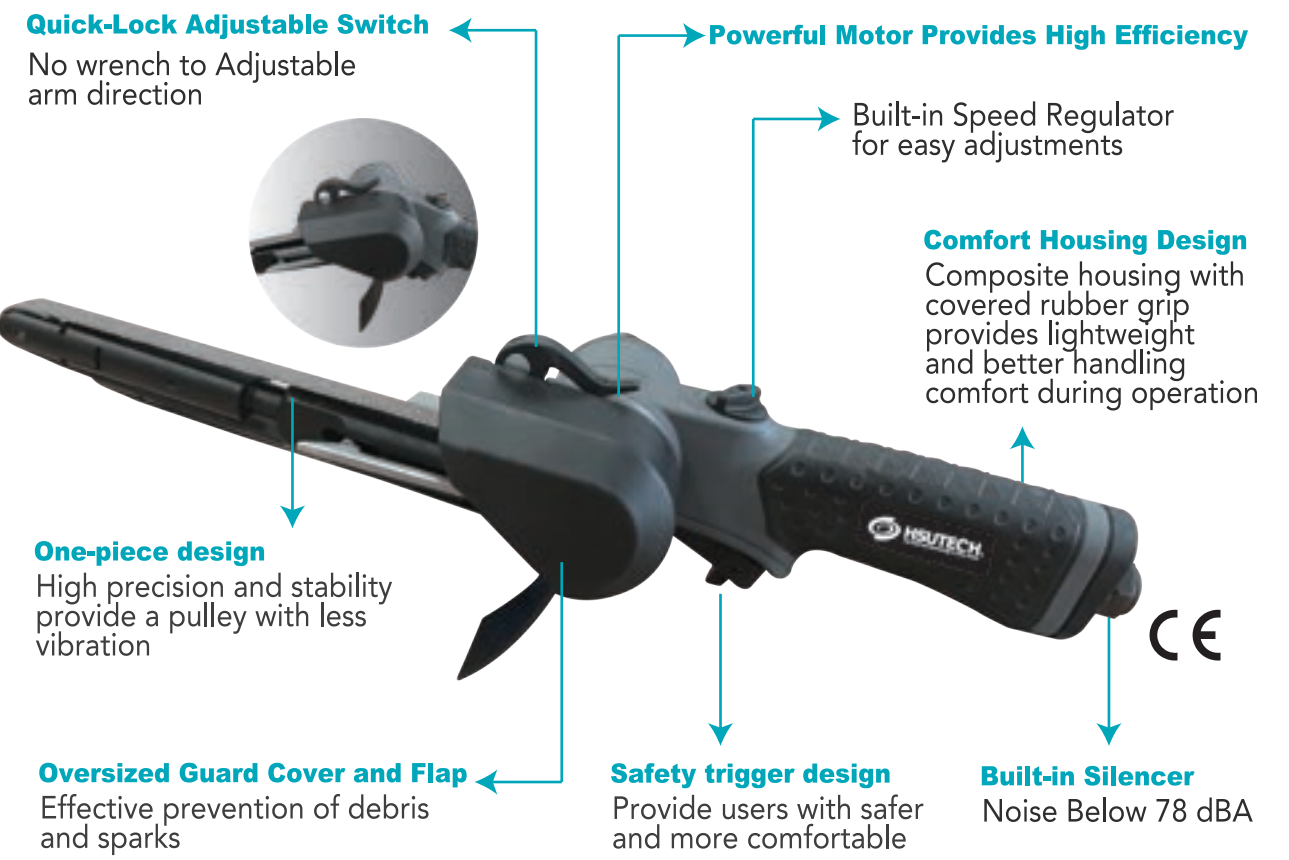
**18000 RPM**  
 Lightweight 0.96 Kgs

- Excellent for paint removal, smoothing, and rust removal applications
- High speed 18000 RPM for versatile sanding applications
- Ergonomic comfortable handle design
- Built-in Speed Regular for easy adjustments
- Quick-Lock device for quick adjustable sanding arm

MODEL	Belt Size		Free Speed (RPM)	Overall Length (mm)	AIR INLET (inch)	HOSE Air Hose I.D (inch (mm))	Avg. Air Consumption (cm <sup>3</sup> /L/min)	Vibration (M/S <sup>2</sup> )	Noise Level (dBA)	Net Weight (KG)
	mm	inch								
HAS-BS706	10X330	3/8x13	18000	325	1/4"	3/8"(10)	3.5(99)	0.59	82	0.78
HAS-BS7076	12.7X330	1/2x13	18000	325	1/4"	3/8"(10)	3.5(99)	0.98	82	0.78
HAS-BS707	12.7X457	1/2x18	18000	385	1/4"	3/8"(10)	3.5(99)	1.18	82	0.80
HAS-BS708	20X520	3/4x20-1/2	18000	396	1/4"	3/8"(10)	3.8(108)	1.78	82	0.96
HAS-BS709	30X540	1-1/5x21-1/4	18000	400	1/4"	3/8"(10)	3.8(108)	2.91	82	1.10

Recommended Air Pressure 90 psi (6.3 bar)

Impact wrench

Ratchet Wrench

0.35HP Air Tool

0.5HP Air Tool

Rust And Paint Remove Tool

1HP Air Die Grinder

Hyd. Air Riveter

Air Cutting Tool

Air Sander

Air Hammer &amp; Needle Scaler

Clean &amp; Foam Gun

Air Micro Grinder

Impact wrench

Ratchet Wrench

0.35HP Air Tool

0.5HP Air Tool

Rust And Paint Remove Tool

1HP Air Die Grinder

Hyd. Air Riveter

Air Cutting Tool

Air Sander

Air Hammer &amp; Needle Scaler

Clean &amp; Foam Gun

Air Micro Grinder

## HAS-BS7219

### AIR COMPOSITE BELT SANDER (10MM X 330MM)

- Lighter than the aluminum body
- The horsepower is higher than that of ordinary belt sanders.
- Good ergonomics, with appearance patent
- Iron/rubber wheels are optional.
- Handheld Antifreeze
- Adjustable speed
- Rear exhaust - the handle presents 30° so that it will not spray the wrist



CE

## HAS-BS7218

### AIR COMPOSITE BELT SANDER (13MM X 457MM)

- Lighter than the aluminum body
- The horsepower is higher than that of ordinary belt sanders.
- Good ergonomics, with appearance patent
- Iron/rubber wheels are optional.
- Handheld Antifreeze
- Adjustable speed
- Rear exhaust - the handle presents 30° so that it will not spray the wrist



CE

## HAS-BS7217

### AIR COMPOSITE BELT SANDER (20MM X 520MM)

- Lighter than the aluminum body
- The horsepower is higher than that of ordinary belt sanders.
- Good ergonomics, with appearance patent
- Iron/rubber wheels are optional.
- Handheld Antifreeze
- Adjustable speed
- Rear exhaust - the handle presents 30° so that it will not spray the wrist



CE



# CONFORM

# TO YOUR

# OPTIMAL

# ANGLE

## FLEX ANGLE AIR TOOLS

MODEL	Belt Size mm	Motor HP	Free Speed RPM	Overall Length mm	AIR INLET (INCH)	HOSE Air Hose I.D inch (mm)	Avg. Air Consumption (l/min)	Vibration (M/S <sup>2</sup> )	Noise Level (dBA)	Net Weight KG
HAS-BS7219	10X330	0.6	17000	320	1/4"	3/8" (10)	4(113.2)	5.65	84	0.8
HAS-BS7218	13X457	0.6	18000	370	1/4"	3/8" (10)	4(113.2)	5.65	84	0.88
HAS-BS7217	20X520	0.6	16000	430	1/4"	3/8" (10)	4(113.2)	5.65	84	1.4

Recommended Air Pressure 90 psi (6.3 bar)

Impact wrench

Ratchet Wrench

0.35HP Air Tool

0.5HP Air Tool

Rust And Paint Remove Tool

1HP Air Die Grinder

Hyd. Air Riveter

Air Cutting Tool

Air Sander

Air Hammer &amp; Needle Scaler

Clean &amp; Foam Gun

Air Micro Grinder



## ADJUSTABLE FLEX AIR SANDER & POLISHER SERIES



### HAD-A7254

#### ADJUSTABLE FLEX ANGLE DIE GRINDER (WITH 3 SPEED REGULATOR CONTROL)

- Safety-lock trigger
- 360° Swivel air exhaust design
- Three-speeds regulator control
- Composite housing lightweight
- Flexible multi-angle adjustable for various work directions and hand-holding

MODEL	COLLET SIZE inch(mm)	Motor HP	Free Speed RPM			Overall Length mm	AIR INLET INCH	HOSE Air Hose I.D inch (mm)	Avg. Air Consumption cfm(L/min)	Vibration (M/S <sup>2</sup> )	Noise Level (dBA)	Net Weight KG
			1	2	3							
HAD-A7254	1/4"(6)	0.45	12500	15200	18500	210	1/4"	3/8"(10)	3.2(90.6)	2.5	85	0.75

Recommended Air Pressure 90 psi (6.3 bar)

### HAS-72512

#### 2" ADJUSTABLE FLEX AIR DISC SANDER (WITH 3 SPEED REGULATOR CONTROL)

### HAS-72513

#### 3" ADJUSTABLE FLEX AIR DISC SANDER (WITH 3 SPEED REGULATOR CONTROL)

- Safety-lock trigger
- 360° Swivel air exhaust design
- Three-speeds regulator control
- Composite housing lightweight
- Flexible multi-angle adjustable for various work directions and hand-holding
- It is suitable for processing surfaces, even in hard-to-reach work areas, etc. removing rust, stripping paint, eliminating adhesive, and sealing residues

### HAS-72522

#### 2" ADJUSTABLE FLEX AIR POLISHER (WITH 3 SPEED REGULATOR CONTROL)

### HAS-72523

#### 3" ADJUSTABLE FLEX AIR POLISHER (WITH 3 SPEED REGULATOR CONTROL)

- Safety-lock trigger
- 360° Swivel air exhaust design
- Three-speeds regulator control
- Composite housing lightweight
- Flexible multi-angle adjustable for various work directions and hand-holding
- A rotation speed of 3200 RPM is excellent for polishing headlamps, and windshields, as well as small area repairs and finishing

### HAS-72502

#### 2" ADJUSTABLE FLEX AIR ORBITAL SANDER (WITH 3 SPEED REGULATOR CONTROL)

### HAS-72503

#### 3" ADJUSTABLE FLEX AIR ORBITAL SANDER (WITH 3 SPEED REGULATOR CONTROL)

- Safety-lock trigger
- 360° Swivel air exhaust design
- Three-speeds regulator control
- Composite housing lightweight
- Flexible multi-angle adjustable for various work directions and hand-holding
- 3 mm orbital action to make the sanding effect more uniform and smoother

MODEL	Sanding Pad Capacity (inch)	Spindle Size (inch)	Motor HP	Free Speed RPM			Overall Length mm	AIR INLET (INCH)	HOSE Air Hose I.D inch (mm)	Avg. Air Consumption cfm(L/min)	Vibration (M/S <sup>2</sup> )	Noise Level (dBA)	Net Weight KG
				1	2	3							
HAS-72512	2"	1/4"-20T	0.45	9300	14000	18000	206	1/4"	3/8"(10)	3.5(99.1)	2.5	83	0.66
HAS-72513	3"	1/4"-20T	0.45	9300	14000	18000	206	1/4"	3/8"(10)	3.5(99.1)	2.5	83	0.66
HAS-72522	2"	5/16"-24T / M6	0.45	1700	2500	3200	206	1/4"	3/8"(10)	3.5(99.1)	2.5	83	0.84
HAS-72523	3"	5/16"-24T / M6	0.45	1700	2500	3200	206	1/4"	3/8"(10)	3.5(99.1)	2.5	83	0.84
HAS-72502	2"	5/16"-24T / M6	0.45	10000	15000	18000	206	1/4"	3/8"(10)	3.5(99.1)	2.5	83	0.75
HAS-72503	3"	5/16"-24T / M6	0.45	10000	15000	18000	206	1/4"	3/8"(10)	3.5(99.1)	2.5	83	0.75



Impact wrench

Ratchet Wrench

0.35HP Air Tool

0.5HP Air Tool

Rust And Paint Remove Tool

1HP Air Die Grinder

Hyd. Air Riveter

Air Cutting Tool

Air Sander

Air Hammer &amp; Needle Scaler

Clean &amp; Foam Gun

Air Micro Grinder

Impact wrench

Ratchet Wrench

0.35HP Air Tool

0.5HP Air Tool

Rust And Paint Remove Tool

1HP Air Die Grinder

Hyd. Air Riveter

Air Cutting Tool

Air Sander

Air Hammer &amp; Needle Scaler

Clean &amp; Foam Gun

Air Micro Grinder





**5" & 6" RANDOM ORBITAL SANDER**



- Low vibration excellent for swirl-free polishing applications
- Durable and lightweight low-profile sanding pad with a balanced design is included
- Extended throttle lever design provides super comfort on the end-user's hand-wrist area and is user-friendly for long operating periods



**(NON-VACUUM)**  
**2.5 mm Random Orbital Sander**  
HAS-725-N5 (5" / 125 mm)  
HAS-725-N6 (6" / 150 mm)

**(CENTRAL VACUUM)**  
**2.5 mm Random Orbital Sander**  
HAS-725-CV5 (5" / 125 mm)  
HAS-725-CV6 (6" / 150 mm)

**(SELF-GENERATED VACUUM)**  
**2.5 mm Random Orbital Sander**  
HAS-725-SV5 (5" / 125 mm)  
HAS-725-SV6 (6" / 150 mm)

MODEL	Pad Size inch(mm)	Spindle Thread inch(mm)	Free Speed RPM	Orbital Diameter inch(mm)	Air Inlet inch	Air Hose I.D inch (mm)	Avg. Air Consumption cfm(L/min)	Noise Level (dBA)	Vibration (M/S <sup>2</sup> )	Net Weight KG
HAS-725-N5/CV5/SV5	5"(125)	5/16"-24UNF	Max. 12000	3/32"(2.5)	1/4"	3/8(10)	3.0 (85)	80	0.8	0.9
HAS-725-N6/CV6/SV6	6"(150)	5/16"-24UNF	Max. 12000	3/32"(2.5)	1/4"	3/8(10)	3.0 (85)	80	0.8	0.9

Recommended Air Pressure at 90 psi (6.2bar)

**OPTION:  
Safety throttle lever**



**Wrist Support  
for Max. comfort**

**Features and Benefits:**

- Models 2.5mm (3/32") and 5mm (3/16") orbit options
- Non vacuum, central vacuum and self vacuum options
- 1", 3", 5" and 6" "hook & loop" pad options
- Only 3.0 CFM average air consumption and 6.2 CFM continuous running under load
- Advanced silencing technology reduces noise levels to 80 d(B)A
- Patented double sealed, lubrication free motor prevents dust contamination of the air motor and eliminates the need for oiling
- Orbital sanders feature the "smooth throttle lever design" and "optimized ergonomics low profile" providing unmatched comfort on end-user's hand wrist area and user-friendly for long operating periods
- Patented "anti vibration" motor reduces vibration level to 0.8 m/sec2
- Low weight: Orbital sanders 0.9 kgs
- Low profile: Orbital sanders 93mm high

**5" & 6" RANDOM ORBITAL SANDER**



- Low vibration excellent for swirl-free polishing applications
- Durable and lightweight low-profile sanding pad with a balanced design is included
- Extended throttle lever design provides super comfort on the end-user's hand-wrist area and is user-friendly for long operating periods



**(NON-VACUUM)**  
**5 mm Random Orbital Sander**  
HAS-107-N5 (5" / 125 mm)  
HAS-107-N6 (6" / 150 mm)

**(CENTRAL VACUUM)**  
**5 mm Random Orbital Sander**  
HAS-107-CV5 (5" / 125 mm)  
HAS-107-CV6 (6" / 150 mm)

**(SELF-GENERATED VACUUM)**  
**5 mm Random Orbital Sander**  
HAS-107-SV5 (5" / 125 mm)  
HAS-107-SV6 (6" / 150 mm)

MODEL	Pad Size inch(mm)	Spindle Thread inch(mm)	Free Speed RPM	Orbital Diameter inch(mm)	Air Inlet inch	Air Hose I.D inch (mm)	Avg. Air Consumption cfm(L/min)	Noise Level (dBA)	Vibration (M/S <sup>2</sup> )	Net Weight KG
HAS-107-N5/CV5/SV5	5"(125)	5/16"-24UNF	Max. 12000	3/16"(5)	1/4"	3/8"(10)	3.0(85)	80	0.8	0.9
HAS-107-N6/CV6/SV6	6"(150)	5/16"-24UNF	Max. 12000	3/16"(5)	1/4"	3/8"(10)	3.0(85)	80	0.8	0.9

Recommended Air Pressure at 90 psi (6.2bar)



## PROFESSIONAL AIR SANDER / POLISHER

**BEST CHOICE**

### 3" RANDOM AIR ORBITAL SANDERS / POLISHER

- Low vibration excellent for swirl-free polishing applications
- Durable and lightweight low-profile sanding pad with a balanced design is included
- Extended throttle lever design provides super comfort on the end-user's hand-wrist area and is user-friendly for long operating periods

#### HAS-3107N

3" Random Orbital Sander  
(NON VACUUM)



#### HAS-3107CV

3" Random Orbital Sander  
(CENTRAL VACUUM)



#### HAS-3107SV

3" Random Orbital Sander  
(SELF VACUUM)



MODEL	Pad Size inch(mm)	Spindle Thread inch(mm)	Free Speed RPM	Orbital Diameter inch(mm)	Air Inlet inch	Air Hose I.D inch (mm)	Avg. Air Consumption cfm(L/min)	Noise Level (dBA)	Vibration (M/S <sup>2</sup> )	Net Weight KG
HAS-3107N	3"(76)	5/16"-24UNF	Max. 12000	3/32"(2.5)	1/4"	3/8"(10)	3.0(85)	80	0.8	0.6
HAS-3107CV	3"(76)	5/16"-24UNF	Max. 12000	3/32"(2.5)	1/4"	3/8"(10)	3.0(85)	80	0.8	0.6
HAS-3107SV	3"(76)	5/16"-24UNF	Max. 12000	3/32"(2.5)	1/4"	3/8"(10)	3.0(85)	80	0.8	0.6

Recommended Air Pressure at 90 psi (6.2bar)

#### HAS-3107PK

##### 3" RANDOM ORBITAL BUFFER

Excellent for Swirl-Free polishing  
The best air polisher in the world



#### HAS-7525CV / HAS-7550CV

##### 6" RANDOM ORBITAL SANDER

Velcro Pad with 52 Multi-holes for Maximum Vacuum Power



MODEL	Pad Size inch(mm)	Spindle Thread inch(mm)	Free Speed RPM	Orbital Diameter inch (mm)	Air Inlet inch	Air Hose I.D inch (mm)	Avg. Air Consumption L/min	Noise Level (dBA)	Vibration (M/S <sup>2</sup> )	Net Weight KG
HAS-3107PK	3"(76)	5/16"-24UNF	Max. 12000	3/16"(5)	1/4"	3/8"(10)	3.0(85)	80	0.8	0.4
HAS-7525CV	3"(76)	5/16"-24UNF	Max. 12000	3/32"(2.5)	1/4"	3/8"(10)	3.0(85)	80	0.8	0.9
HAS-7550CV	3"(76)	5/16"-24UNF	Max. 12000	3/16"(5)	1/4"	3/8"(10)	3.0(85)	80	0.8	0.9

Recommended Air Pressure at 90 psi (6.2bar)

## HEAVY DUTY AIR SANDERS / POLISHER

### 3" RANDOM AIR ORBITAL SANDERS / POLISHER

- Low vibration excellent for swirl-free polishing applications
- Durable and lightweight low-profile sanding pad with a balanced design is included
- Extended throttle lever design provides super comfort on the end-user's hand-wrist area and is user-friendly for long operating periods
- Resilient silicone palm grip for excellent operation comfort

#### HAS-3315

3" Random Orbital Buffer  
(LARGE ORBITAL 15 MM)



#### HAS-3315N

3" Random Orbital Sander  
(NON VACUUM)



#### HAS-3315CV

3" Random Orbital Sander  
(CENTRAL VACUUM)



#### HAS-3315SV

3" Random Orbital Sander  
(SELF-VACUUM)



MODEL	Pad Size inch(mm)	Spindle Thread inch(mm)	Free Speed RPM	Orbital Diameter inch(mm)	Air Inlet inch	Air Hose I.D inch (mm)	Avg. Air Consumption cfm(L/min)	Noise Level (dBA)	Vibration (M/S <sup>2</sup> )	Net Weight KG
HAS-3315	3"(76)	5/16"-24UNF	Max. 12000	9/16"(15)	1/4"	3/8"(10)	2.5 (71)	71	3	0.7
HAS-3315N	3"(76)	5/16"-24UNF	Max. 12000	3/32"(2.5)	1/4"	3/8"(10)	2.5 (71)	71	3	0.7
HAS-3315CV	3"(76)	5/16"-24UNF	Max. 12000	3/32"(2.5)	1/4"	3/8"(10)	2.5 (71)	71	3	0.7
HAS-3315V	3"(76)	5/16"-24UNF	Max. 12000	3/32"(2.5)	1/4"	3/8"(10)	2.5 (71)	71	3	0.7

Recommended Air Pressure at 90 psi (6.2bar)

### 5" & 6" RANDOM ORBITAL SANDER

- Low vibration excellent for swirl-free polishing applications
- Durable and lightweight low-profile sanding pad with a balanced design is included
- Extended throttle lever design provides super comfort on the end-user's hand-wrist area and is user-friendly for long operating periods
- Resilient silicone Palm Grip for excellent operation comfort



(NON-VACUUM)  
(Large Orbital 9 mm)

Random Orbital Sander  
HAS-515-N5 (5" / 125 mm)  
HAS-515-N6 (6" / 150 mm)

(NON-VACUUM)

2.5 mm Random Orbital Sander  
HAS-525-N5 (5" / 125 mm)  
HAS-525-N6 (6" / 150 mm)  
5 mm Random Orbital Sander  
HAS-505-N5 (5" / 125 mm)  
HAS-505-N6 (6" / 150 mm)

(CENTRAL VACUUM)

2.5 mm Random Orbital Sander  
HAS-525-CV5 (5" / 125 mm)  
HAS-525-CV6 (6" / 150 mm)  
5 mm Random Orbital Sander  
HAS-505-CV5 (5" / 125 mm)  
HAS-505-CV6 (6" / 150 mm)

(SELF-GENERATED VACUUM)

2.5 mm Random Orbital Sander  
HAS-525-SV5 (5" / 125 mm)  
HAS-525-SV6 (6" / 150 mm)  
5 mm Random Orbital Sander  
HAS-505-SV5 (5" / 125 mm)  
HAS-505-SV6 (6" / 150 mm)

MODEL	Pad Size inch(mm)	Spindle Thread inch(mm)	Free Speed RPM	Orbital Diameter inch (mm)	Air Inlet inch	Air Hose I.D inch (mm)	Avg. Air Consumption cfm(L/min)	Noise Level (dBA)	Vibration (M/S <sup>2</sup> )	Net Weight KG
HAS-515-N5	5"(125)	5/16"-24UNF	Max. 12000	3/8"(10)	1/4"	3/8"(10)	2.5 (71)	81	3	0.9
HAS-515-N6	6"(150)	5/16"-24UNF	Max. 12000	3/8"(10)	1/4"	3/8"(10)	2.5 (71)	81	3	0.9
HAS-525-N5/CV5/SV5	5"(125)	5/16"-24UNF	Max. 12000	3/32"(2.5)	1/4"	3/8"(10)	2.5 (71)	71	3	0.9
HAS-505-N5/CV5/SV5	5"(125)	5/16"-24UNF	Max. 12000	3/16"(5)	1/4"	3/8"(10)	2.5 (71)	71	3	0.9
HAS-525-N6/CV6/SV6	6"(150)	5/16"-24UNF	Max. 12000	3/32"(2.5)	1/4"	3/8"(10)	2.5 (71)	71	3	0.9
HAS-505-N6/CV6/SV6	6"(150)	5/16"-24UNF	Max. 12000	3/16"(5)	1/4"	3/8"(10)	2.5 (71)	71	3	0.9

Recommended Air Pressure at 90 psi (6.2bar)

Impact wrench

Ratchet Wrench

0.35HP Air Tool

0.5HP Air Tool

Rust And Paint Remove Tool

1HP Air Die Grinder

Hyd. Air Riveter

Air Cutting Tool

Air Sander

Air Hammer &amp; Needle Scaler

Clean &amp; Foam Gun

Air Micro Grinder

# REVOLUTIONARY VIBRATION DAMPED AIR HAMMER

## Extremely Low Vibrations Level & Ultra-high Beating Power

### Benefit

- Vibration damping system + Active air spring = Significant decrease in Hammer Vibration
- Aluminum housing is equipped with a covered rubber grip to enhance operating comfort during work
- Provide more powerful hammer beating while yielding low vibration

### Features

- Quick-change retainer chuck
- Ultra-high beating power
- Direct air away from the user
- Extremely powerful handheld tool

### Damping System + Active Air Spring = Perfect!

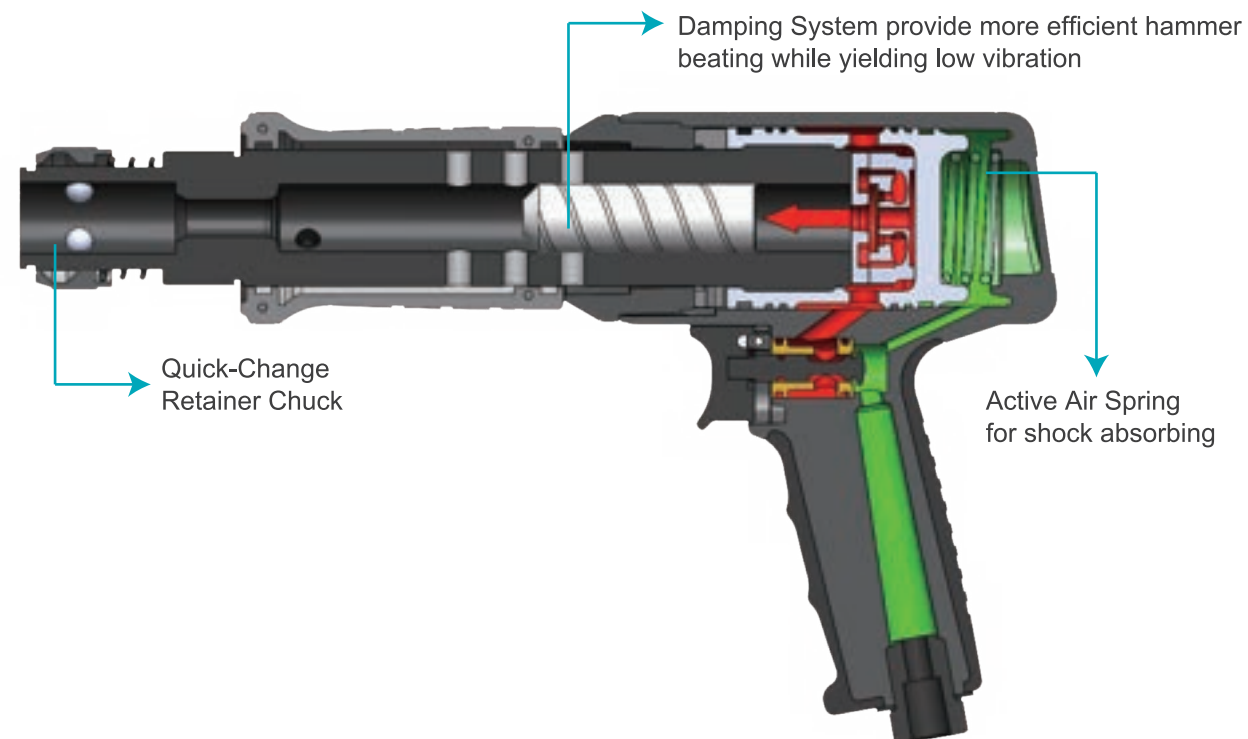

### HMM-20615

150MM SHORT BARREL VIBRATION DAMPED AIR HAMMER



### HMM-20619

190MM MEDIUM BARREL VIBRATION DAMPED AIR HAMMER



### HMM-20625

250MM LONG BARREL VIBRATION DAMPED AIR HAMMER



MODEL	Blow Per Min	Overall Length (mm)	Beating Power(Kgf)	Shank Opening (inch/mm)	Avg. Air Consumption (L/min)	Bore Dia (inch/mm)	Stroke Length (inch/mm)	Vibration (M/S <sup>2</sup> )	Net Weight (KG)
HMM-20615	4000	200	600	0.41"(10.4)	3.7(104.8)	0.75"(19)	1.2"(30.1)	2.4229	1.8
HMM-20619	3500	242	850	0.41"(10.4)	3.4(96.3)	0.75"(19)	2.3"(58)	3.1407	2.2
HMM-20625	2500	290	1085	0.41"(10.4)	3.1(88)	0.75"(19)	3.5"(89)	4.093	2.5

Impact wrench

Ratchet Wrench

0.35HP Air Tool

0.5HP Air Tool

Rust And Paint Remove Tool

1HP Air Die Grinder

Hyd. Air Riveter

Air Cutting Tool

Air Sander

Air Hammer &amp; Needle Scaler

Clean &amp; Foam Gun

Air Micro Grinder



Impact wrench

Ratchet Wrench

0.35HP Air Tool

0.5HP Air Tool

Rust And Paint Remove Tool

1HP Air Die Grinder

Hyd. Air Riveter

Air Cutting Tool

Air Sander

Air Hammer &amp; Needle Scaler

Clean &amp; Foam Gun

Air Micro Grinder

Impact wrench

Ratchet Wrench

0.35HP Air Tool

0.5HP Air Tool

Rust And Paint Remove Tool

1HP Air Die Grinder

Hyd. Air Riveter

Air Cutting Tool

Air Sander

Air Hammer &amp; Needle Scaler

Clean &amp; Foam Gun

Air Micro Grinder

## HNS-3000LRN

**BEST CHOICE**

### 13 NEEDLES MINI PENCIL NEEDLE SCALER

- For removing rust, paint, impurities, scales... on metals, woods, cement or other hard objects
- Mini size, straight & handy, easily reach to narrow, confined space, meticulous work piece
- Low vibrations & low sound pressure benefits to smooth operations
- It can be held like a pencil for easier handling, Detail of surface cleaning work
- It can be handling the cleaning work of details more reliably, and will not hurt smaller parts

#### Needle (Ø1.4x80mm)

13 pcs needle, Ø1.4, 60mm outside length, ensure smoothly work in details.

#### 360° Adjustable Air Exhaust

#### Speed Regulator

Adjustable for various needs of speed

#### Safety Trigger

Operation workable only if press the handle lever

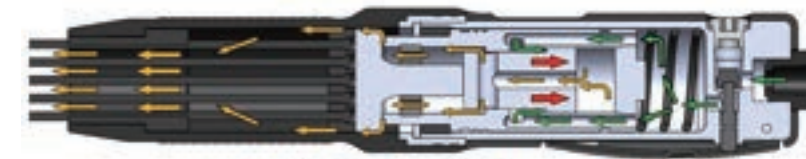

Green indicates the inlet direction.

Yellow indicates the exhaust direction.

Red indicates the hammering movement direction



Green indicates the inlet direction.

Red indicates the hammering movement direction



## HNS-201

### 12 NEEDLES NEEDLE SCALER

- Low vibration
- Damping System provide more efficient hammer beating while yielding low vibration
- The only air spring used in needle scaler



## HNS-202

### 19 NEEDLES NEEDLE SCALER

- Low vibration
- Damping System provide more efficient hammer beating while yielding low vibration
- The only air spring used in needle scaler

MODEL	Blow Per Min	Piston Stroke (mm)	Needle (Dia/Length) (mm/cm)	Air Inlet (inch)	HOSE Air Hose I.D (inch/mm)	Overall Length (mm)	Avg. Air Consumption (cfm/L/min)	Noise Level (dBA)	Net Weight (KG)
HNS-3000LRN	3000	24mm	1.4/6	1/4"	3/8"(10)	235.6	1.7(48.1)	89	0.6

MODEL	Blow Per Minute	Needle (Dia/Length) (mm/cm)	Stroke Length (mm)	Overall Length (mm)	Air Inlet (inch)	HOSE Air Hose (inch/mm)	Avg. Air Consumption (cfm/L/min)	Bore Dia (inch/mm)	Vibration (M/S <sup>2</sup> )	Net Weight (KG)
HNS-201	4800	3/18	20	137	1/4"	3/8"(10)	3.5(99)	0.79"(20)	16.04	0.2
HNS-202	4300	3/18	20	150	1/4"	3/8"(10)	3.5(99)	0.91"(23)	16.94	0.23

## HNS-3400LR

### 11 NEEDLES PISTOL NEEDLE SCALER

- Patent needle's inclination at 15°, which can increase 30% efficient on work comparing against any other conventional needle scaler with straight needle design
- Designed for easy maneuverability in narrow spaces, it is both robust and compact, providing enhanced accessibility for your work
- The tool operates smoothly, minimizing vibrations for a more stable performance
- Engineered with ergonomic considerations, it ensures a comfortable grip, reducing the risk of fatigue during extended use
- The unique needle structure of the tool enhances rust removal efficiency, offering a more effective solution



MODEL	Blow Per Min	Piston Stroke (mm)	Needle (Dia/Length) (mm/cm)	Air Inlet (inch)	HOSE Air Hose (inch/mm)	Overall Length (mm)	Avg. Air Consumption (cfm/L/min)	Noise Level (dBA)	Net Weight (KG)
HNS-3400LR	3400	20mm	3/11.5	3/8"(10)	3/8"(10)	214	1.0(28.3)	92	1.4

## HMM-20615N

### (2 in 1) 150MM SHORT BARREL AIR HAMMER



MODEL	Blow Per Min	Overall Length (mm)	Beating Power (Kgf)	Shank Opening (inch/mm)	Avg. Air Consumption (cfm/L/min)	Bore Dia (inch/mm)	Stroke Length (inch/mm)	Vibration (M/S <sup>2</sup> )	Net Weight (KG)	
HMM-20615N (2in1)	Needle Scaler	4000	180	600	0.41"(10.4)	3.7(104.8)	0.75"(19)	1.2"(30.1)	2.4229	1.57
	Hammer	4000	267	600	0.41"(10.4)	3.7(104.8)	0.75"(19)	1.2"(30.1)	2.4229	2.16

Impact wrench

## HCG-2014BSS

### MULTI-FUNCTION BLOW SUCTION GUN SET (SMALL SIZE OF DUST COLLECTING COVER + 4 PCS OF BLACK ADAPTOR )



Unique method  
 At the same time for bellowing operations  
 \*Using a detergent to wash away the dirt  
 \*Suck dirt away through the vacuum cleaner



Ratchet Wrench

0.35HP Air Tool

0.5HP Air Tool

Rust And Paint Remove Tool

1HP Air Die Grinder

Hyd. Air Riveter

Air Cutting Tool

Air Sander

Air Hammer &amp; Needle Scaler

Clean &amp; Foam Gun

Air Micro Grinder

## HWG-0210K

### AIR WONDER GUN KIT

AIR WONDER GUN KIT ( ALUMINUM HOUSING)  
 Air Suction / Blow Gun Kit / Aluminum Housing  
 Accepted 25 kg (435 PSI / 3.0 Mpa) pressure  
 One-touch button for the Suction & Blow function  
 Pressure: 6.3 Bar  
 Air Inlet (PT): 1/4"  
 1. 0201G14: Flexible Tube x 1  
 2. 0201G16: Extension Tube x 1  
 3. 0201G17: Clamping Ring x 2  
 4. 0201G15-5: Dust Bag x 1  
 5. 0204B02 : Small Diameter Tube x 1  
 6. 0204B03 : Flat Tube x 1  
 7. 0204G04 : Brush x 1  
 8. 0204B06S: Vacuum Hose x 1



## HCG-0100S

### PROFESSIONAL CLEANING GUN WITH STAINLESS STEEL NOZZLE & RUBBER GRIP



## HCG-0300

### FOAM GUN W/ 1 LITER TANK

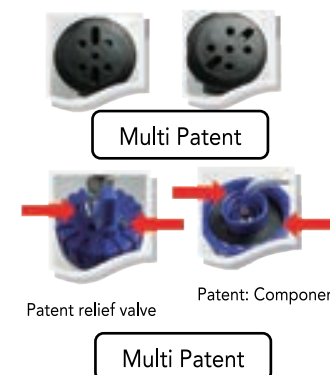









## HBG-203

### POCKET TYPE AIR TWISTER BLOW GUN

- Wide range of sprays
- Highly efficient dust removal and dewatering
- Superb for cleaning buffs
- Handy pocket size that fits well, making it convenient for frequent use at work



MODEL	 Free Speed	 Overall Length mm	 Air Inlet inch	 HOSE Air Hose LD inch (mm)	 Avg. Air Consumption cfm(L/min)	 Vibration (M/S <sup>2</sup> )	 Noise Level (dBA)	 Net Weight KG
HBG-203	5500	156	1/4"	3/8"(10)	6(170)	0.86	98.1	0.17

Impact wrench

Ratchet Wrench

0.35HP Air Tool

0.5HP Air Tool

Rust And Paint Remove Tool

1HP Air Die Grinder

Hyd. Air Riveter

Air Cutting Tool

Air Sander

Air Hammer &amp; Needle Scaler

Clean &amp; Foam Gun

Air Micro Grinder



Impact wrench

Ratchet Wrench

0.35HP Air Tool

0.5HP Air Tool

Rust And Paint Remove Tool

1HP Air Die Grinder

Hyd. Air Riveter

Air Cutting Tool

Air Sander

Air Hammer &amp; Needle Scaler

Clean &amp; Foam Gun

Air Micro Grinder

Impact wrench

Ratchet Wrench

0.35HP Air Tool

0.5HP Air Tool

Rust And Paint Remove Tool

1HP Air Die Grinder

Hyd. Air Riveter

Air Cutting Tool

Air Sander

Air Hammer &amp; Needle Scaler

Clean &amp; Foam Gun

Air Micro Grinder

## HEP-C01

### AIR ENGRAVING PEN

- It can work in areas with restricted access
- Sturdy metal housing
- Noise-dampened
- Slim design and optimized haptics
- Anti-kink spring prevents the hose from kinking
- Knurled power control



CE

MODEL	Blow Per Minute	Overall Length (mm)	Hose Assy Length (mm)	Air Inlet (inch)	HOSE Air Hose I.D. (inch (mm))	Avg. Air Consumption (cfm(L/min))	Vibration (M/S <sup>2</sup> )	Noise Level (dBA)	Net Weight (KG)
HEP-C01	13000	140	1420	1/4"	3/8"(10)	1(28.3)	2.5	78	0.22

## HMD-864

### AIR PENCIL DIE GRINDER W/KEVLAR ROTOR BLADE

- Motor can work without gears
- The machine is less prone to overheat during prolonged use
- Lightweight and exquisite pen-like style design
- Lightweight and ideal for tight spots
- Twist throttle provides variable speed control
- Designed for high-speed porting and finishing of small parts



CE

## HMD-868

### 110° OFF-SET GEARLESS ANGLE MICRO DIE GRINDER W/KEVLAR ROTOR BLADE

- Motor can work without gears
- The machine is less prone to overheat during prolonged use
- Lightweight and exquisite pen-like style design
- Lightweight and ideal for tight spots
- Twist throttle provides variable speed control
- Designed for high-speed porting and finishing of small parts



CE

MODEL	Free Speed (RPM)	Motor HP	Overall Length (mm)	Air Inlet (inch)	Collet Size (inch (mm))	Air Hose Size (inch)	Avg. Air Consumption (cfm (L/min))	Vibration (M/S <sup>2</sup> )	Noise Level (dBA)	Net Weight (KG)
HMD-864	70000	0.6	137	1/4"	1/8"(3)	3/8"	1(28.3)	1.1	81	0.2
HMD-868	70000	0.6	150	1/4"	1/8"(3)	3/8"	1(28.3)	2	72	0.23

## HMD-056H

### INDUSTRIAL AIR PENCIL DIE GRINDER W/KEVLAR ROTOR BLADE

- Collet 3 mm



CE

## HMD-35000

### INDUSTRIAL AIR PENCIL DIE GRINDER

- Collet 3 mm & 6 mm



CE

MODEL	COLLET SIZE (inch/mm)	Free Speed (RPM)	Dia (mm)	AIR INLET (inch)	Air Hose Dia (mm)	HOSE Air Hose I.D. (mm)	Avg. Air Consumption (cfm(L/min))	Vibration (M/S <sup>2</sup> )	Noise Level (dBA)	Net Weight (KG)
HMD-056H	3	30000	325	1/4"	min.5	1500	2.6(75)	0.8	80.4	0.23
HMD-35000	3+6	60000	425	1/4"	min.5	1500	1.6(46)	1.8	78.7	0.38

Recommended Air Pressure 90 psi (6.3 bar)

Impact wrench
Ratchet Wrench
0.35HP Air Tool
0.5HP Air Tool
Rust And Paint Remove Tool
1HP Air Die Grinder
Hyd. Air Riveter
Air Cutting Tool
Air Sander
Air Hammer & Needle Scaler
Clean & Foam Gun
Air Micro Grinder

Impact wrench
Ratchet Wrench
0.35HP Air Tool
0.5HP Air Tool
Rust And Paint Remove Tool
1HP Air Die Grinder
Hyd. Air Riveter
Air Cutting Tool
Air Sander
Air Hammer & Needle Scaler
Clean & Foam Gun
Air Micro Grinder